



الجامعة الإسلامية للتكنولوجيا

ISLAMIC UNIVERSITY OF TECHNOLOGY (IUT)

ORGANISATION OF ISLAMIC COOPERATION (OIC)

COURSE STRUCTURE  
AND  
COURSE CONTENTS

Department of

**Electrical and Electronic Engineering (EEE)**

January, 2016

## Preface

The Department of Electrical and Electronic Engineering (EEE) is the largest departments of Islamic University of Technology (IUT). The department has more than fifteen years of glorious history of excellence in undergraduate and post-graduate teaching and research. The department aims at producing the best engineers, teachers and professionals for national and international arena. To cope with the rapidly changing scenarios in this field, updating the course curricula, expanding laboratory facilities and revising teaching and/or research materials are regular activities of EEE department. Although limited by financial and logistic resources, the department constantly tries to revise, renew and introduce courses so that our students remain at par with students of other standard universities in the world. The syllabus presented in this course calendar is the part of this ongoing change to meet the needs of present EEE students so that they can meet their carrier requirements in national and international forums.

The syllabus and the course offering listed in this catalog are prepared by teachers of the department with the help, cooperation and feedback from our ex-graduates and some renowned faculties abroad. Course catalogs of many universities of USA, Canada, UK, Australia, Singapore and India have been consulted in preparing the syllabus of this calendar. It is different from our previous syllabus in many aspects. Students can now choose their field of specialization from any of the four cluster of elective courses, i.e. Power System, Communication, Electronics, and Signal Processing & Interdisciplinary without sacrificing the fundamental and basic study of core courses of electrical and electronic engineering. As a result of this and other major changes in course contents, the laboratory materials have also changed with more design oriented classes having

emphasis on both practical and simulation components. The department has developed many facilities for such changes to be incorporated effectively and effort is also underway to improve the situation further.

General information about IUT with a brief history and a short description of the Department of EEE have been presented in this catalog. This catalog highlights about the faculty strength of the department, their educational background and research interests. Names of the laboratories existing in the department are also listed. General information is followed by some major rules and regulations of the university regarding the undergraduate and post-graduate study at this university. Rest of this catalog devotes to the sequence of the course offering to the undergraduate students of the department. The course offering is structured with options available in the later semesters after 4<sup>th</sup> semester. Contents of EEE courses, including those offered to students of other departments (excluding EEE) of the university are also provided in this calendar.

Students and relevant individuals are advised to be in touch with their advisors and the department office to learn about any changes made by the department in any courses and in the rules and regulations of the university.

Dhaka  
January, 2016

Head,  
Department of Electrical and Electronic  
Engineering

# **CONTENTS**

## **Preface**

## **Message from the Vice-Chancellor**

## **1. General Information: Islamic University of Technology**

### 1.1 Origin

### 1.2 Location

### 1.3 Vision and Mission

#### 1.3.1 Vision

#### 1.3.2 Mission

### 1.4 Administration

### 1.5 Objectives and Function

### 1.6 Structure

### 1.7 Authoritative bodies

#### 1.7.1 Joint General Assembly

#### 1.7.2 Governing Board

#### 1.7.3 Syndicate

#### 1.7.4 Academic Council

#### 1.7.5 Statutory Committees

## **2. Academic Rules and Regulations**

### 2.1 Academic Calendar

### 2.2 Medium of Instructions

### 2.3 Admission

- 2.4 Admission Requirements
  - 2.4.1 Undergraduate Programs
  - 2.4.2 Postgraduate Programs
- 2.5 Course Registration Procedure and Requirements
- 2.6 Student Advisory System
- 2.7 Grading Systems
  - 2.7.1 Postgraduate Programmes in Engineering
  - 2.7.2 Undergraduate Programmes in Engineering and all Programmes of Technical Education
- 2.8 Student Feedback System

### **3. Department of Electrical and Electronic Engineering**

- 3.1 Introduction
- 3.2 Vision and Mission of the Department
  - 3.2.1 Vision
  - 3.2.2 Mission
- 3.3 List of Faculty and Staff Members with Field of Expertise
- 3.4 Study Programmes
  - 3.4.1 Undergraduate Programmes
  - 3.4.2 Postgraduate Programmes
- 3.5 Labs and Facilities under Electrical and Electronic Engineering Department

## **4. Detailed Course Information**

### 4.1 Course Structure for Undergraduate Programme

#### 4.1.1 Course Credit Distribution Table

#### 4.1.2 Course Designation and Numbering System

#### 4.1.3 Category-wise Course Structure

#### 4.1.4 Semester-wise Course Structure

#### 4.1.7 Semester-wise Elective Course Structure

### 4.2 Course Structure for Postgraduate Programme

### 4.3 Course Syllabus

#### 4.3.1 Contents of Undergraduate Courses

##### 4.3.1.1 Courses Offered by EEE Department to EEE Students

##### 4.3.1.2 Courses Offered by Other Departments to EEE Students

#### 4.3.2 Contents of Postgraduate Courses

#### 4.3.3 Contents of EEE Courses Offered to Other Departments

##### 4.3.3.1 Undergraduate Programmes

##### 4.3.3.2 Postgraduate Programmes

## **Message from the Vice-Chancellor**

A university is the highest seat of learning and a place for freethinking. It is a melting pot for the academicians and those who want to be taught. It is a place for research, creation of knowledge and dissemination of the same. All these, of course, need a congenial atmosphere. The Islamic University of Technology (IUT) has been established to provide such an environment to the youth of the member states.

The real wealth of a country lies not only in its natural resources but much in the quality of education of its people and their ability to use their knowledge for national development. It is an undeniable fact that the Islamic world is lagging behind the developed world in the key fields of science and technology although many of them are blessed with considerable natural resources. Therefore human resources development remains as one of the cherished objectives of the OIC. We have to understand also that if science, technology and the scientists are not linked to the economic system, we shall be facing a disastrous consequence in the development our nations.

The dawn of the new millennium has been a historic turning point for the human race. It has marked the beginning of a new era of globalization and a knowledge-based economy, which puts a very high priority on to the role of Science and Technology. In the highly competitive world, the youth of the Islamic world must be equipped with the necessary know-how and expertise, especially in the area of new and cutting-edge technologies. Special emphasis must be given to the programs in engineering and technology in order to boost industrial and technological research.

There are many universities in the world. Not all of them enjoy the same status in terms of ranking. So what makes a university superior

than the others? In my judgment what comes first in this respect is the presence of properly qualified, experienced and dedicated academicians. Then come the physical facilities like good classroom, well equipped laboratories, good research facilities, resourceful library with up-to-date text books, reference books and journals. Dynamic course curriculum and standard examination system are also vital in determining the status of a university. At IUT we are trying to ensure the above within our limited resources.

Students also constitute a major component of a university. Unless we have students with the right academic background preparation, they will not be able to cope with demand of the courses that are offered. The end result may be a waste of time and money for both the students and the university. We cannot allow the Islamic world to continue to be permanent consumer of technology but rather we should work seriously to join the group of technology providers. We must develop our own scientific and technological capabilities. With these hopes and aspirations, we urge all concerned from the OIC countries particularly those who are directly related with the activities of IUT to contribute their might to build IUT as a center of Excellence.

In order to provide quality education to the students, it is essential to constantly review the course curricula. The Departmental Committees, Syllabus Committees and Postgraduate Committees (PGC) of different departments have reviewed and updated course curricula and designed new courses for both undergraduate and postgraduate programmes and modified several existing courses. The present edition of IUT Calendar incorporates all these changes. I take this opportunity to deeply appreciate the contributions made by different academic committees, Academic Council and the Governing Board to help improve academic programmes. I am grateful to the Member



States, Honourable Secretary General and the General Secretariat of the OIC for their guidance and support. I also acknowledge the contributions made by the Heads of Departments and Offices, Expert Members of different committees, Faculty Members and specially the Department of Research, Extension, Advisory Services and Publication (REASP) for bringing out this updated version of IUT Calendar. I hope that the information provided here will be useful to the interested persons.

Prof. Dr. Imtiaz Hossain  
Ph.D. (UMIST), M.Sc.Engg, B.Sc. Engg. (Mech), (BUET)  
Vice Chancellor, IUT

# Chapter 1

## General Information:

### Islamic University of Technology

#### 1.1 Origin

Islamic University of Technology at Dhaka, Bangladesh commonly known as IUT is a subsidiary organ of the Organization of the Islamic Conference (OIC), representing fifty seven member countries from Asia, Africa, Europe and South America.

It was initially established as the Islamic Centre for Technical and Vocational Training and Research, ICTVTR in pursuance of the Resolution No. 5/9-E of the Ninth Islamic Conference of Foreign Ministers (ICFM) held in Dakar, Senegal in 1978. The foundation stone of ICTVTR was laid on 27 March 1981 by His Excellency Late Ziaur Rahman, the President of Bangladesh in the presence of His Excellency Late Yasir Arafat, President of Palestine and Late Dr. Habib Chatty, the then Secretary General of the OIC on the 30-acre land donated by the Government of the People's Republic of Bangladesh to the OIC.

ICTVTR was renamed as the Islamic Institute of Technology (IIT), by the Twenty-second ICFM held in Casablanca, Kingdom of Morocco in 1994. It is mandated to help develop human resources in the Member Countries of the OIC in the fields of engineering and technology as well as technical education.

The process of renaming Islamic Institute of Technology (IIT) as Islamic University of Technology (IUT) began with a discussion in the 25th meeting of the Governing Board of IIT held in Dhaka, Bangladesh on 20 – 23 November 2000. In course of deliberation, the Honorable Members of the Governing Board felt the necessity of renaming the Institute and decided unanimously the following:

“5.9.13 The Governing Board opined that considering the academic programs being conducted in the fields of engineering, technology and technical

education, and the level it has reached, IIT might be considered as a typical educational Institution of a Technological University, and in order to facilitate its interactions with other Universities of renown, to enable its graduates to pursue their higher studies elsewhere and to attract meritorious students from the Member States of OIC, it is proposed and recommended that the Institute may be renamed as “Islamic University of Technology” after fulfilling appropriate procedural requirements.”

The recommendation of the Governing Board set in motion the issue of renaming and necessitated the raising of the matter in different hierarchies of authorities of the Institute. After getting the required clearance from the Governing Board, the above proposal was placed before the 24th Session of the Islamic Commission for Economic, Cultural and Social Affairs (ICECSA) held in Jeddah, Kingdom of Saudi Arabia on 10 – 13 February 2001, which also acted as the General Assembly of the Institute and was approved unanimously vide recommendation No. 48/24-E (Clause – 5) on activities of the Islamic Institute of Technology (IIT), Dhaka which reads as follows:

“5. Approves the proposal to rename the Institute as ‘Islamic University of Technology (IUT)’ as recommended by the Governing Board, without any financial implications”.

The Honorable Secretary General of the Organization of the Islamic Conference (OIC) in his report on Science and Technology as a follow-up of above recommendation, reflected in the report of ICECSA, submitted to the 28th Session of the Islamic Conference of Foreign Ministers (ICFM) held in Bamako, Republic of Mali on 25 – 27 June 2001 highlighted the issue of renaming which reads as follows:

“The Islamic Institute of Technology (IIT), Dhaka, Bangladesh was established by Resolution No. 5/9-E of the 9th ICFM with the name of “Islamic Centre for Technical and Vocational Training and Research (ICTVTR)”. The Institute was renamed by Resolution No. 27/22-E of the 22nd ICFM as **Islamic Institute of Technology (IIT)**. The Institute provides a professional training leading to engineering degrees in various technical sectors. Name of the Institute is proposed to be changed into **Islamic University of Technology (IUT)**.

As the institute constitutes a privileged instrument of inter-Islamic cooperation in the domain of specialized human resources, it should be

supported financially and morally, in its strive to attain state of the art academic standards.”

Following the recommendation of the ICECSA and report of the Secretary General and on the recommendation of the Committee for Economic and Social Affairs, the following remarkable decision was adopted on 27 June 2001 in the final Plenary of the 28th Session of ICFM vide Resolution No. 48/28-E on activities of Islamic Institute of Technology (IIT), Dhaka:

“Approves the proposal to rename the Institute as ‘Islamic University of Technology (IUT)’ as recommended by the Governing Board, without any financial implication.”

The decision of the 28th Session of the ICFM was made public through Final Communiqué, relevant extract of which is as follows:

“124. The Conference commended the activities of the Islamic Institute of Technology in Dhaka, decided that the Institute should become a university without financial implications, with the title “The Islamic University of Technology”, and encouraged it to continue its efforts in developing the human resources of Member States in the area of science and technology.”

The renaming of IIT as IUT is an important milestone in the annals of this unique educational institution, only of its kind under the umbrella of the OIC which has been emerging as the most visible demonstration of the Islamic Solidarity and Joint Islamic Action under the Makkah – Al – Mukarramah Declaration.

IUT is basically an educational and research institution offering a wide range of undergraduate and postgraduate academic programs conducted in the fields of engineering, computer science & information technology and teacher training. It also offers knowledge and skill updating and upgrading short and special courses as needed by the Member States. International and regional seminars and workshops are also arranged regularly by IUT to provide forums and to keep abreast of the latest technological developments. It also undertakes technological and industrial research projects, promotes technical cooperation, exchanges technical know-how and disseminates basic information of development of human resources as co-focal point under UN-OIC collaboration among the Member States of the OIC. IUT ensures coordination between its objectives with other national and regional institutions of the Islamic countries as well as with international institutions.

It also undertakes advisory and consultancy services for Government, International Bodies, Foundations and allied Organizations.

## **1.2 Location**

The University is located at Board Bazar, Gazipur, about 30 km north of Dhaka (Latitude=23°43'N, Longitude = 90°25'E), the capital of Bangladesh. The capital is served by an international airport with widely developed airlines network with the rest of the world and by satellite telecommunication.

## **1.3 Vision and Mission**

### **1.3.1 Vision**

IUT looks forward to become a unique and prestigious multicultural hub of higher learning particularly in engineering, technology and relevant fields offering state-of-the-art multi-disciplinary programmes and cutting-edge research for sustainable growth of the Islamic world.

The vision of IUT is elaborated in the following points:

- Develop itself as a successful university which will be known world-wide for its quality, relevance, depth and scope;
- Produce graduates in all fields of engineering, technology and technical education to support the industrial development of the Islamic world;
- Upgrade its laboratories, library, faculty and research facilities matching the demand of the day;
- Promote human and intellectual diversity of its graduates to overcome the barriers separating individuals, nations and cultures;
- Collaborate with the public and private enterprises of the host country and other OIC member-states for enhancing the knowledge of the students.

### **1.3.2 Mission**

The mission of Islamic University of Technology (IUT) is to serve the OIC member states in particular and the entire world in general by producing technical professionals in an Islamic environment who would play leading roles in promoting the Islamic World's competitiveness for integration into global economy.

In the 21st century, science and technology is at the heart of all development activities. It is therefore essential that if the Islamic world wants to march forward in right pace with the contemporary world, it has to educate and train its youngsters with science and technology. The OIC established the Islamic University of Technology (IUT) with the same intention. The university offers academic programs with a view to produce graduates in the fields of engineering, technology and technical education. The university encourages its students and faculty members to undertake research work on current issues and thereby create new knowledge on different disciplines of engineering, technology and technical education.

## **1.4 Administration**

### **Chancellor**

Secretary General of OIC

### **Vice-Chancellor**

### **Administrative Officers**

Registrar

Comptroller

Librarian

Chief of Establishment

Chief of Planning & Development

Chief Medical Officer

Sr. Sub-Divisional Engineer

### **Heads of Academic Departments**

Head, Mechanical and Chemical Engineering (MCE) Department

Head, Electrical and Electronic Engineering (EEE) Department

Head, Technical and Vocational Education (TVE) Department

Head, Computer Science and Engineering (CSE) Department

Head, Civil and Environmental Engineering (CEE) Department

### **Heads of Non-academic Department & Centers**

Head, Research, Extension, Advisory Services and Publications (REASP)

Head, Computer Center

Head, Energy and Environment Centre (EEC)

### **Provost of Residential Halls**

Provost, Halls of Residence

### **Chairmen of Different Committees**

Chairman, Admission Committee  
Chairman, Examination Committee  
Chairman, Library Committee  
Chairman, Industrial Training Committee  
Chairman, Games & Sports Committee  
Chairman, Religious Affairs Committee  
Chairman, Students Welfare Committee  
Chairman, Cafeteria Committee  
Chairman, Social Activities Committee

## **1.5 Objectives and Function**

The Islamic University of Technology is basically an educational and research institution. The main objective of the University is to help generally in human resources development in member states of the OIC, particularly in different fields of engineering, technology and technical education.

In fulfillment of its objectives, the University undertakes, among others, the following necessary and appropriate functions:

- Provide instruction in engineering, technology and technical and vocational education and in such branches of learning connected with the above fields as per requirement of the Member States and as approved the Conference, and in particular, train instructors, technicians in technologies needed in the Member States and to upgrade the midlevel and lower level manpower to international standards.
- Conduct, promote and guide research in engineering, in industrial and technological fields and in technical and vocational education to the benefits of the Member States of the OIC.
- Hold examination and grant and confer certificates, degrees, diplomas and other academic distinctions on persons who have pursued courses of study provided by the University and have passed the examinations of the University under such conditions as may be prescribed by the academic rules and regulations of the University.



- May confer other academic distinctions on persons of high eminence of the Member States with the approval of the general assembly on the recommendation of the Board.
- Promote technical cooperation, exchange technical know-how and disseminate basic information in the field of human resource development through short and special courses, seminars, workshops and publications.
- Ensure coordination between the objective of the University with other national and regional institutions of the Islamic Countries as well as with international institutions.
- Undertake advisory and consultancy services for government, International Bodies and foundations or allied organizations.
- Participate in the meetings of commissions and committees established by the Conference with appropriate background and technical papers.
- Cooperate and collaborate with the General Secretariat, and with other subsidiary and affiliated organs of the conference.
- Any other relevant functions as may be decided from time to time.

## 1.6 Structure

The structure of the University comprises the Joint General Assembly, the Governing Board, Syndicate and the Vice Chancellor. The internal setup and working conditions of the University are governed by its Internal Rules and Regulations as approved by the Islamic Conference of Foreign Ministers (ICFM) as well as by the provisions of the Personnel and Financial Regulations of the OIC.

The Vice Chancellor of the University is the chief executive in charge of the overall management of the University and takes measures necessary for realizing the objectives of the University. The Member States cooperate in every possible manner to assist the University in pursuing its objectives. The budget of the University is financed by mandatory contributions of the Government of the Member States in proportion to their contribution to the budget of the General Secretariat of the Organization of the Islamic Conference.

## **1.7 Authoritative Bodies**

### **1.7.1 Joint General Assembly**

The Islamic Commission for Economic, Cultural and Social Affairs consisting of all Member States of the OIC acts as Joint General Assembly of the Subsidiary Organs including IUT. The Joint General Assembly acting as General Assembly of the University has power to

- Determine the general policy of the University and provide the general guidance to it.
- Examine the activity program of the University and submit its recommendations to the Islamic Conference of Foreign Ministers (ICFM).
- Examine and approve the Internal Rules and Regulations governing the internal activities of the University.
- Elect the members of the Governing Board for a specific period.
- Examine the whole budget which is prepared on programme basis prior to its submission to the Permanent Finance Committee (PFC).
- Consider and submit the final accounts of the University for approval of the ICFM, after having been audited by the Finance Control Organ (FCO).

## 1.7.2 Governing Board

The Governing Board is composed of

- Ten members including a member of the Host Country to be elected by the Joint General Assembly from amongst experienced and competent candidates in the field of activities of the University proposed by Member States, with due regard to the principle of equitable geographical distribution to the extent possible.
- The Secretary General of the OIC or his representative and the Vice Chancellor of IUT as ex-officio members.

The Governing Board has power to

- Formulate program policies and exercises technical supervision over the activities of the University. It also focuses on consideration of the program of action and the report on the activities of the University and submits its recommendations to the Joint General Assembly.
- Examine the program budget and final accounts of the University prior to their submission to the Joint General Assembly.
- Consult the General Secretariat about the measures to be taken by the University to promote its objectives.
- Frame the Internal Rules and Regulations of the University prior to its submission to the Joint General Assembly for approval.
- Approve the curricula of training and research programs on the recommendation of the Academic Council of the University.
- Confer and grant degrees, diplomas and certificates as per approved academic regulations of the University.

Current Governing Board of IUT is given below:

| <b>Governing Board (2016)</b>   |                        |
|---|------------------------|
| Representative of the People's Republic of Bangladesh                       | Member                 |
| Representative of the Republic of Cameroon                                  | Member                 |
| Representative of the Republic of Turkey                                    | Member                 |
| Representative of Malaysia  | Member                 |
| Representative of Nigeria   | Member                 |
| Representative of the Islamic State of Afghanistan                          | Member                 |
| Representative of Libya   | Member                 |
| Representative of the Kingdom of Saudi Arabia                               | Member                 |
| Representative of the United Arab Emirates                                  | Member                 |
| Representative of Uganda  | Member                 |
| Representative of H.E. the Secretary General of the OIC & Chancellor of IUT | Member<br>(Ex-officio) |
| Vice-Chancellor, IUT  | Member<br>(Ex-officio) |

### 1.7.3 Syndicate

The Syndicate of the Governing Board consists of the following:

- Vice-Chancellor of IUT.
- Four Heads of Diplomatic Missions of the Member States in Bangladesh nominated by the Governing Board.
- Representative of the Education Ministry of the host country not below the rank of Joint Secretary.
- The Vice Chancellor of Bangladesh University of Engineering and Technology (BUET) or his Representative not below the rank of Professor.
- Two Heads of Academic Departments of IUT nominated by the Vice-Chancellor.
- One senior Professor nominated by the Vice-Chancellor.
- One senior Professor nominated by the Academic Council.
- Registrar of IUT.

The Syndicate of the Governing Board is empowered to deal with any matter that may be referred to it by the Vice Chancellor or that may be delegated by the Governing Board. All interim actions of the Syndicate are reported to the Governing Board.

Current Syndicate of Governing Board of IUT is given below:

| <b>The Syndicate (2016)</b>  |                  |
|--|------------------|
| Vice-Chancellor, IUT   | Chairman         |
| Representative of the Embassy of the Kingdom of Saudi Arabia in Bangladesh | Member           |
| Representative of High Commission of Pakistan in Bangladesh                | Member           |
| Representative of the Embassy of the Republic of Turkey in Bangladesh      | Member           |
| Representative of the United Arab Emirates in Bangladesh                   | Member           |
| Join Secretary, Ministry of Education, Government of Bangladesh            | Member           |
| Professor, Department of Mechanical Engineering, BUET, Dhaka               | Member           |
| Head, EEE Department, IUT  | Member           |
| Head, MCE Department, IUT  | Member           |
| Professor, MCE Department, IUT   | Member           |
| Professor, EEE Department, IUT   | Member           |
| Registrar, IUT   | Member-Secretary |

## 1.7.4 Academic Council

The Academic Council consists of the following:

- Vice-Chancellor of IUT.
- Representatives from five Embassies / High Commissions of the Member States in Dhaka, Bangladesh nominated by the Governing Board.
- The Vice-Chancellor of Dhaka University of Engineering & Technology (DUET), Gazipur, Bangladesh.
- The Director General of Technical Education, Government of the People's Republic of Bangladesh.
- Representative of the Education Ministry, Government of the People's Republic of Bangladesh not below the rank of Additional Secretary.
- A Chairman of Public Sector Industrial Corporation, to be nominated by the Government of the People's Republic of Bangladesh.
- One Professor of the Bangladesh University of Engineering and Technology (BUET), to be nominated by the Vice-Chancellor of the University.
- All Heads of Academic Departments of IUT.
- All Professors of Academic Departments of IUT.
- Registrar of IUT.

Subject to other provisions, the Academic Council has power to

- Advise the Governing Board on all academic matters.
- Make Regulations for the proper conduct of teaching, training and examinations, and for promoting academic life in the University and for the award of Fellowships, Scholarships, Medals and Prizes.
- Propose to the Governing Board for constitution of Departments and Departmental Committees of the University.
- Lay down conditions under which the students / trainees may be given admission to the various courses of studies and the examinations held by the University.
- Approve the results of examinations conducted by the University
- Prescribe, subject to the approval of the Governing Board and upon the recommendations of the Syllabus Committee, the courses of

studies, the Syllabuses and the outlines of texts for all the examinations.

- Recognize the examinations of other Institutes or Institutions, Boards and Universities as equivalent to the corresponding examinations of the University.

The Academic Council, within the provisions of these regulations, appoints the Admission Committee, the Syllabus Committees and the Examination Committee for the purpose of Trainees / Students' admission, formulation of Syllabuses and conducting examinations respectively.

Current Academic Council of IUT is given below:

| <b>Academic Council (2016)</b>   |                   |
|--|-------------------|
| Vice-Chancellor, IUT   | Chairman          |
| Representative of the Embassy of Afghanistan in Dhaka                                | Member            |
| Representative of the Embassy of Egypt in Dhaka                                      | Member            |
| Representative of the Embassy of Indonesia in Dhaka                                  | Member            |
| Representative of the Embassy of Libya in Dhaka                                      | Member            |
| Representative of the High Commission of the Islamic Republic of Pakistan in Dhaka   | Member            |
| Vice-Chancellor, DUET, Gazipur, Bangladesh   | Ex-officio Member |
| Additional Secretary, Ministry of Education, Govt. of Bangladesh                     | Ex-officio Member |
| Director General, Directorate of Technical Education, Govt. of Bangladesh            | Ex-officio Member |
| Chairman, Bangladesh Steel Engineering Corporation, Steel House, Kawran Bazar, Dhaka | Ex-officio Member |
| Dean, Faculty of Mechanical Engineering, BUET, Dhaka.                                | Ex-officio Member |
| Head, MCE Department, IUT  | Member            |
| Head, EEE Department, IUT  | Member            |
| Head, TVE Department, IUT  | Member            |
| Head, CSE Department, IUT  | Member            |

|                                 |                     |
|---------------------------------|---------------------|
| Head, CEE Department, IUT       | Member              |
| Professors, EEE Department, IUT | Members             |
| Professors, MCE Department, IUT | Members             |
| Professors, CEE Department, IUT | Members             |
| Professors, CSE Department, IUT | Members             |
| Registrar, IUT                  | Member<br>Secretary |



## 1.7.5 Statutory Committees

Besides, among others, there are the following Statutory Committees to ensure proper management of programs and activities in the relevant and related fields.

### Finance Committee

Finance Committee consists of the following:

| <b>Finance Committee</b>  |          |
|---|----------|
| Vice-Chancellor, IUT  | Chairman |
| Representative of the Embassy of the Republic of Turkey in Bangladesh                                   | Member   |
| Representative of the Ministry of Finance (Nominee of the Govt. of the People's Republic of Bangladesh) | Member   |
| Representative of the Embassy of UAE in Bangladesh  | Member   |
| Representative of the Embassy of Kingdom of Saudi Arabia in Bangladesh                                  | Member   |

### Selection Committee

Selection Committee consists of the following:

| <b>Selection Committee (OIC Staff)</b>  |          |
|---|----------|
| Vice-Chancellor, IUT  | Chairman |
| Representative of the Govt. of the People's Republic of Bangladesh                      | Member   |
| Representative of the High Commission of Malaysia in Bangladesh                         | Member   |
| Representative of the Embassy of the Kingdom of Morocco in Bangladesh                   | Member   |
| Representative of the Embassy of the State of Palestine in Bangladesh                   | Member   |
| Representative of the High Commission of the Islamic Republic of Pakistan in Bangladesh | Member   |

| <b>Selection Committee (Faculty Members)</b>                                |          |
|---|----------|
| Vice-Chancellor, IUT  | Chairman |
| Head, MCE Department, IUT   | Member   |
| Head, EEE Department, IUT   | Member   |
| Head, CSE Department, IUT   | Member   |
| Head, CEE Department, IUT   | Member   |
| Head, TVE Department, IUT   | Member   |
| Head, REASP Department, IUT   | Member   |
| One external expert for each Department<br>Nominated by the Vice-Chancellor | Member   |

**Other Statutory Committees:**

- Administrative Advisory Committee
- Departmental Committee
- Disciplinary Committee
- Planning and Development Committee
- Research Committee
- Syllabus Committee

# **Chapter 2**

## **Academic Rules and Regulation**

### **2.1 Academic Calendar**

IUT follows the Semester System for the purpose of conduct of instructions and examinations. An academic year consists of two semesters each of sixteen weeks of instruction. They are winter semester and summer semester. There is also a short semester in between summer semester of the last academic year and winter semester of the upcoming academic year to facilitate the industrial training for IUT students of all departments and arrangement of short courses by all departments on different need basis professional topics.

### **2.2 Medium of Instructions**

The official languages of the University are Arabic, English and French. Medium of instructions and examinations at present is English. A crash English Language Programme is arranged for Arabic and French speaking students when needed. All students are required to learn one of the three languages as second language. However, all non-Arabic speaking students are required to learn Arabic as spoken language.

### **2.3 Admission**

The Islamic University of Technology (IUT) announces for each academic year it's offering of programs in Doctor of Philosophy, Masters of Science, Masters of Engineering, Bachelor of Science, Higher Diploma and Diploma under various academic departments. Nominations of eligible candidates for admission to different programs of study are invited from the relevant Ministries or Authorities of the Member States by the end of September. Nominations for the programs are to be sent to IUT in order of merit on the basis of tests prescribed by the University and conducted by the Nominating Authority and Focal Points of the Member States of the OIC.

Each nomination should be accompanied with Application of the nominee in the prescribed form duly filled in and signed, available in the office of the Nominating Authority and Focal Points, along with attested copies of Academic Certificates and Mark Sheets. Reports from an authorized Medical Board or Medical Practitioner on eyesight, hearing and general fitness for prolonged mental and physical exertion, blood and urine, chest X-ray and contagious and communicable diseases. Candidates having contagious and communicable diseases e.g. tuberculosis, venereal diseases, AIDS, HIV positive, hepatitis B, etc. are not eligible for admission.

Final selection of students for admission from amongst the nominated candidates of all the Member States will be made by IUT on the basis of merit, geographical distribution and option given by the candidates. If, however, the number of eligible candidates for a particular program / specialization is not sufficient in a particular academic year, it will not be offered. The selected candidates are required to take admission by reporting to the Registrar on or before the date of beginning of the academic year as specified by the Registrar.

## **2.4 Admission Requirement**

IUT offers programs of various durations. The entrance requirements for different programs of study for which enrolment is sought are detailed below:

### **2.4.1 Undergraduate Programmes**

4-Year Bachelor of Science programmes in Mechanical and Chemical Engineering (MCE), Electrical and Electronic Engineering (EEE), Computer Science and Engineering (CSE), and Civil and Environmental Engineering (CEE) require Higher / Upper Secondary School Certificate in Science from a Board / University or its equivalent. The candidates are required to have good grades in Mathematics, Physics, Chemistry and English. 3-Year Higher Diploma programmes have the same entry requirements as those of Bachelor of Science programmes.

## **2.4.2 Postgraduate Programmes**

For admission to Ph.D. program, a candidate must have obtained M.Sc. Engg./ M. Engg./ M.Sc. degree in the relevant branch or equivalent degree from any recognized institution, having a minimum CGPA of 3 out of 5 or 2.5 out of 4 in the relevant Masters Programme. For admission to the courses leading to the award of the Degree of M.Sc.Engg./M.Engg./M.Sc. in any branch, a candidate must have obtained B.Sc. Engg./ 4-year B. Sc. Degree in the relevant branch or equivalent from any recognized institution, having a minimum CGPA of 3.0 out of 5 or 2.5 out of 4 in the relevant Bachelors program and good performances in other examinations.

## **2.5 Course Registration Procedure and Requirements**

Every student in IUT has an account in Student Information System (SIS) implemented by IUT KPI Quality Assurance unit. At the beginning of each semester, each student has to register his required courses for that semester in SIS consulting with his advisor. Details procedure of course registration process is given in “Student Guide”.

## **2.6 Student Advisory System**

All Advisors do the job of advising of his assigned students as per the guidelines given below:

1. An Advisor will maintain contact with his advisee at regular intervals throughout the academic year. For this purpose, the Advisor may call meetings with the students once or twice in each month.
2. The Advisor will advise and guide the student in all matters in order to solve academic problems faced by the students during his stay at IUT and may discuss personal problems which may affect academic pursuit.
3. Discussion with the students may include the important points of the “Students Guide” so that the students follow the instructions given in the Guide Book meticulously.

4. Each student should also be reminded about the requirement of the minimum percentage of attendance in relation to his current percentage of attendance both in theory and lab classes. Information about submission of lab reports and home assignments in time should also be discussed.
5. They should also discuss the existing situation regarding attending the class tests and quiz examination by each and every student.
6. They may also be advised to take good preparation before regular examinations, class tests and quizzes, so that they may avoid the Referred Examination and Automation system, i.e. cancellation of admission in case of two consecutive failures.
7. The students coming from outside Bangladesh should be reminded of their own responsibility for getting their visa extended well before the expiry date in order to avoid heavy fine for each day of delay. The Protocol Officer will render all possible help in this respect.

## **2.7 Grading Systems**

### **2.7.1 Postgraduate Programmes in Engineering**

The minimum duration of the M.Sc. Engg., M.Sc. and M. Engg. programmes shall normally be three semesters each consisting of 16 weeks. A candidate for the Masters Degree must complete all requirements for the Degree within a maximum period of five calendar years from the date of his admission. Academic progress shall be measured in terms of credit hours earned by a student. One credit hour subject shall require one hour of lecture per week for one semester, while one credit hour for thesis/project/ /sessional/special studies should normally require two hours of work per week for one semester. The number of credit hours for each subject is specified in the syllabus of the respective Department. The number of subjects to be offered per semester will be decided by Postgraduate Committee (PGC) but a student cannot register for more than 12 credit hours per semester. For the Degree of M.Sc. Engg./ M.Sc., a student must earn a minimum total of 36 credit hours, including a Thesis for which a total of 18 credit hours shall be assigned. For the Degree of M. Engg., a student must earn a minimum total of 36 credit hours including a Project for which a total of 6 credit hours shall be assigned.

The course curriculum and subject of study of the different departments shall be as recommended by the respective PGC, checked by the Committee for Advanced Studies and Research (CASR) and approved by the Academic Council. Departmental Post Graduate Committee (PGC) may review the curriculum from time to time and recommend any changes as may be considered necessary and get it finally approved by the Academic Council. For any particular semester the courses to be offered will be decided by the PGC.

The grading system is as follows:

| <b>Marks obtained<br/>(in percentage)</b> | <b>Letter Grade</b> | <b>Grade Point</b> |
|---|---------------------|--------------------|
| 80 & Above                                | A+                  | 4.00               |
| 75 to <80                                 | A                   | 3.75               |
| 70 to <75                                 | A-                  | 3.50               |
| 65 to <70                                 | B+                  | 3.25               |
| 60 to <65                                 | B                   | 3.00               |
| 55 to <60                                 | B-                  | 2.75               |
| 50 to <55                                 | C+                  | 2.50               |
| 45 to <50                                 | C                   | 2.00               |
| Less than 45                              | F                   | 0.00               |
|   | I                   | Incomplete         |
|   | W                   | Withdrawn          |
|   | S                   | Satisfactory       |
|   | U                   | Unsatisfactory     |

The minimum average **GPA** for pass will be 2.5. Courses in which the student gets **F** shall not be counted towards credit requirements and for the calculation of Grade Point Average (GPA). Grade **I** is given only when a student is unable to sit for the examination of a course at the end of semester because of circumstances beyond his control. **W** grade will be given to a student who withdraws in writing from a course four weeks before the completion of the semester. **S** & **U** grades will be given in case of thesis only.

Detailed rules and regulations governing Ph.D. and Masters Programmes are available in a separate publication on rules for postgraduate programmes.

## 2.7.2 Undergraduate Programmes in Engineering and all Programmes of Technical Education

For sixteen weeks' instruction period per semester, each period of instruction per week in a theory subject or theoretical part of a subject constitutes one "unit" or 1.00 Credit Hour and carries 100 marks. Three periods per week in a sessional subject or sessional part of a subject or tutorial part of a subject constitutes 1.50 Credit Hour and carries 150 marks. Two periods per week in a sessional subject or tutorial part of a subject constitute 1.00 Credit Hour and carries 100 marks.

Examination in a theory course / theoretical part of a course consists of the following four parts:

|                               |                     |
|-------------------------------|---------------------|
| 1. Class attendance           | 10% of total marks  |
| 2. Class test / Quiz          | 15 % of total marks |
| 3. Mid-semester Examination   | 25% of total marks  |
| 4. Semester-final Examination | 50% of total marks  |

For class attendance, the marks are distributed as follows:

| <b>Attendance</b> | <b>Marks</b> |
|-------------------|--------------|
| 95% and above     | 10%          |
| 90% - <95%        | 8%           |
| 85% - <90%        | 6%           |
| 80% - <85%        | 4%           |
| 75% - <80%        | 2%           |
| Below 75%         | 0%           |

Four quizzes are held and distributed evenly over the semester. The best three quiz results are considered. Mid Semester Examination is usually held around the middle of the semester on the portion of the syllabuses covered by then. Semester Final Examination covers the entire syllabus.

Final grade in theoretical / theoretical part of a course shall be on the basis of the total aggregate of marks secured by the student in attendance, quizzes, mid-semester examination and semester final examination. A student



missing any quiz or the mid-semester or the semester final examinations shall be considered to have got zero in that quiz or the examination of the course.

The tutorial part of a course shall be assessed continuously throughout the semester in the form of quizzes, homework and library assignments. Marks so obtained shall be added with that of corresponding theoretical or sessional course.

The sessional or sessional part of a course shall be assessed continuously throughout the semester. In addition a final examination may be conducted. If a student fails in any sessional or practical class he is not allowed to sit in the written Semester Final Examination.

Final grades in all courses are recorded in letter grades on the basis of aggregate marks. For any course a student must secure 40% or above of the total aggregate marks to pass the course.

As per decision and approval of the 51<sup>st</sup> Academic council the grading system is as follows:

| <b>Marks obtained<br/>(in percentage)</b> | <b>Letter Grade</b> | <b>Grade Point</b> |
|---|---------------------|--------------------|
| 80 & Above                                | A+                  | 4.00               |
| 75 to <80                                 | A                   | 3.75               |
| 70 to <75                                 | A-                  | 3.50               |
| 65 to <70                                 | B+                  | 3.25               |
| 60 to <65                                 | B                   | 3.00               |
| 55 to <60                                 | B-                  | 2.75               |
| 50 to <55                                 | C+                  | 2.50               |
| 45 to <50                                 | C                   | 2.25               |
| 40 to <45                                 | D                   | 2.00               |
| Less than 40                              | F                   | 0.00               |

Total grade points secured divided by the total Credit Hours taken shall be computed as Grade Point Average (GPA). A student is declared to have passed the semester examinations when he passes in all the courses of the semester having minimum GPA of 2.00 for all undergraduate programmes.

The required minimum GPA for passing a semester in the postgraduate programmes is 2.50.

A student failing in not more than two theoretical courses may be allowed to sit for Referred Examination on the course or courses to be held normally within two weeks from the commencement of the next semester. The Referred Examinations will cover the entire syllabus of the course(s). Those failing in any sessional course will not be eligible for Semester Final or Referred Examinations.

A student who passes the Referred Examinations shall be declared to have passed the relevant Semester Examination. **The grading for a subject will be according to the grading system mentioned above with maximum of B grade.** If he fails in the Referred Examinations he may seek re-admission as per rules. A re-admitted student may be exempted from repeating the subject in which he secured minimum of C grade in the examinations in which he failed.

A student failing in three or more theoretical subjects in a semester final examination or in referred subjects will be provisionally allowed to attend classes in the next higher semester with a maximum of four theoretical subjects having no pre-requisite subject and sessional which will be decided by the Head of the Department.

Results of examinations of the successful candidates and of those eligible for referred examinations are announced by the Registrar subject to the approval of the Academic Council after it has been considered by the Examination Committee and endorsed by the Vice Chancellor. A student is eligible for award of Certificate, Diploma, Higher Diploma, Bachelor Degree, and Master Degree for which he was admitted when he passes the prescribed subjects of all the semesters and successfully completes approved industrial attachment, special assignments, practical training and remedial courses as the case may be. The details are given in the publication on Academic Rules as approved by the Academic Council.

The awards are classified as

- First Class with Honours
- First Class,
- Second Class.

However, no class is awarded in the case of Master of Technical Education. A student securing Cumulative Grade Point Average (CGPA) of 3.75 and above is placed in the First Class with Honours. Those securing CGPA of 3.00 and above are placed in the First Class. Other successful candidates are placed in the Second Class.

**IUT Gold Medal** is awarded Department-wise to the students who get highest CGPA at the end of the programme but not less than 3.80 out of 4.00 among different programmes of each Department (having duration of 2 years or more) taken together. **OIC Gold Medal** is awarded to a student who secures at least CGPA of 3.90 out of 4.00 at the end of the programme and tops the list of all successful students of all the programmes of all the Departments. However, only OIC Gold Medal will be awarded to the student who becomes eligible for both the medals.

## 2.8 Student Feedback System

At the end of each semester, student has to give his feedback of the courses he taken in that semester in Student Information System (SIS). Details procedure of student feedback is given in “Student Guide”.

# Chapter 3

## Department of Electrical and Electronic Engineering

### 3.1 Introduction

The Department of Electrical and Electronic Engineering (EEE) is the largest department of the Islamic University of Technology (IUT) with an annual intake of 100 undergraduate students. Offering both undergraduate and graduate programs, the department has established itself in a leading position in engineering education in Bangladesh. It offers students a unique hands-on experience in state-of-the-art laboratories and instruction from well qualified and dedicated faculty.

The EEE department always ensures close interaction between students and faculty to extract the best out of the students. It also maintains continuous interactions with industry leaders in areas such as electronics, telecommunication, integrated circuits, power electronics and power system which give an added impetus to the students to acquire strong theoretical foundation and exceptional practical experience.

The EEE department is making major contributions toward the achievement of the cherished goal of IUT in developing human resources of the Member States of Organisation of Islamic Cooperation (OIC), especially in the fields of Engineering, Science and Technology. Different programs are offered by the department to prepare the students to place themselves in the highly competitive world of modern technology.

The Department of Electrical and Electronic Engineering has a vibrant research oriented culture. The department has undertaken research works in various areas of Electrical and Electronic Engineering. These focused areas include power electronics, energy, high power microwave and communication systems and networks, biomedical engineering, control system, intelligent systems, robotics and VLSI circuit design.

Special training programs are also designed and offered on short-term basis as per the request from Member States of OIC. Seminars and Workshops on national and international levels are organized by the department to disseminate information on current progress in Technology and Technical know-how among the personnel of the OIC Member States who are involved in the promotion, development and application of Electrical and Electronic Engineering.

## **3.2 Vision and Mission of the Department**

### **3.2.1 Vision**

To be a place of academic excellence by acquainting the cutting edge technology to face the global challenge, imparting quality teaching, carrying out state of the art research and development in frontier areas of electrical and electronic engineering.

### **3.2.2 Mission**

The mission of our department is to produce electrical and electronic engineers and researchers having strong foundation, good engineering design experience and exposure to high-tech research and development. The mission is also to serve society, muslim ummah in particular and globally in general by educating, creating knowledge and putting knowledge to work on a large scale and with excellence.

### 3.3 List of Faculty and Staff Members with Field of Expertise

#### Present Faculty

##### Faculty

##### Field of Expertise

##### Head of the Department

Prof. Dr. Md. Ashraful Hoque  
Ph.D. (MUN), M. Engg. (MUN), B.Sc. Engg. (BUET)  
Power Electronics circuits and Motor drives

##### Professors

Prof. Dr. Md. Shahid Ullah  
Ph.D. (IIT Kharagpur), M.Sc. Engg. (BUET), B.Sc. Engg. (BUET)  
Load flow study, Stability and short circuit calculation

Prof. Dr. Kazi Khairul Islam  
Ph.D. (IIT Kanpur), M. Tech. (IIT Kanpur), B.Sc. Engg. (RU)  
System & Control, Bio-Medical signal circuits & Instrumentation

Prof. Dr. Md. Ruhul Amin  
Ph.D. (Niigata), M.Sc. Engg. (BUET), B.Sc. Engg. (RU)  
High power microwave and computational electromagnetics

Prof. Dr. Mohammad Rakibul Islam  
Ph.D. (Kyung Hee), M.Sc. Engg. (BUET), MBA (IBA), B.Sc. Engg. (BUET)  
Wireless communication, wireless sensor networks, LDPC code, OFDM, secrecy capacity analysis

##### Associate Professor

Dr. Syed Iftekhar Ali  
Ph.D. (BUET), M.Sc. Engg. (BUET), M.A.Sc. Low power VLSI circuits (Waterloo), B.Sc. Engg. (BUET)

##### Assistant Professors

Mr. Mohammad Tawhid Kawser  
M.Sc. Engg. (Virginia Tech.), B.Sc. Engg. (BUET)  
Wireless communication, Celular communication

|  |  |
|--|--|
| Mr. Golam Sarowar<br>M.Sc. Engg. (BUET), B.Sc. Engg (IUT)                                  | Power Electronics,<br>Microcontroller based design                                 |
| Dr. Md. Fokhrul Islam<br>Ph.D. (UKM), M.Sc. Engg. (UKM), B.Sc.<br>Engg. (RUET)             | RF MEMS, Microstrip Patch<br>Antenna   |
| Mr. Ashik Ahmed<br>M.Sc. Engg. (KFUPM), B.Sc. Engg. (IUT)                                  | Distributed generation,<br>Renewable energy, Power<br>system stability and control |
| Dr. Khondokar Habibul Kabir<br>Ph.D. (Osaka), M.Sc. Engg. (Osaka), B.Sc.<br>Engg. (IUT)    | Wireless communication,<br>Sensor networking, Delay<br>tolerant networking         |
| Mr. Muhammad<br>M.Sc. Engg. (IUT), B.Sc. Engg. (IUT)                                       | Power Electronics  |
| Mr. Nafiz Imtiaz Bin Hamid<br>M.Sc. Engg. (IUT), B.Sc. Engg. (IUT)                         | Wireless communications<br>and networks, Biomedical<br>signal Analysis             |
| Mr. Md. Taslim Reza<br>M.Sc. Engg. (TUT), B.Sc. Engg. (IUT)                                | Signal processing and<br>Medical electronics                                       |
| Muhammad Rezaul Hoque Khan<br>M.Sc. Engg. (BUET), B.Sc. Engg. (IUT)                        | Mobile and<br>telecommunication, Optics  |
| Mr. Rakibul Hasan Sagor<br>M.Sc. Engg. (KFUPM), B.Sc. Engg. (IUT)                          | High power microwave<br>device, Plasmonics   |
| Mr. Abdur Raquib Ridwan<br>M.Sc. Engg. (CEMACUBE), M.Sc. Engg.<br>(IUT), B.Sc. Engg. (IUT) | EEG, FMRI signal<br>processing and biomedical<br>control processing                |
| <b>Lecturers</b>   |  |
| Mr. Md. Monir Hossan Rubel<br>B.Sc. Engg. (IUT)  | VLSI Technology, TCAM<br>technology  |
| Mr. Md. Thesun Al-Amin<br>M.Sc. Engg. (IUT), B.Sc. Engg. (IUT)                             | Nanophotonics , Plasmonics   |
| Mr. Mohammad Wahidur Rahman<br>B.Sc. Engg. (BUET)  | Nanotechnology,<br>Nanomaterials & devices,<br>Solar cell                          |

Mr. Rashid-Al-Mukaddim  
B.Sc. Engg. (IUT)

Biomedical image  
processing, ultrasound  
imaging

Mr. Fahim Faisal  
B.Sc. Engg. (IUT)

Power Electronics,  
Biomedical signal analysis

Mr. Shah Md Ashraful Alam Mohon  
B.Sc. Engg. (BUET)

Renewable energy, power  
electronics

## **Faculty on Leave**

### **Assistant Professors**

Mr. Md. Mosharrof Hossain Sarker  
M.Sc. Engg. (Wolverhampton), B.Sc. Engg. (RUET)

Mr. Mohammad Shafiqur Rahman Tito  
M.Sc. Engg. (Ulm), B.Sc. Engg. (IUT)

Mr. Mohammad Abu Naser  
M.Sc. Engg. (IUT), B.Sc. Engg. (IUT)

### **Lecturers**

Mr. Nayeem Ahmed Ninad  
B.Sc. Engg. (IUT)

Mr. Md. Shahriar Rahman  
B.Sc. Engg. (IUT)

Mr. Tahmid Latif  
B.Sc. Engg. (IUT)

Mr. Md. Riyasat Azim  
M.Sc. Engg. (IUT), B.Sc. Engg. (IUT)

Mr. Md. Abduhu Ruhul Hasin  
M.Sc. Engg. (IUT), B.Sc. Engg. (IUT)



Mr. Md. Murad Hossain  
M.Sc. Engg. (IUT), B.Sc. Engg. (IUT)

Mr. Md. Rezaul Hasan  
M.Sc. Engg. (IUT), B.Sc. Engg. (IUT)

Mr. Md. Rokibul Islam  
B.Sc. Engg. (IUT)

Mr. S.M. Masudur Rahman Al-Arif  
M.Sc. Engg. (IUT), B.Sc. Engg. (IUT)

Mr. Maruf Ahmed Dhali  
M.Sc. Engg. (IUT), B.Sc. Engg. (IUT)

Mr. Niamul Quader  
M.Sc. Engg. (IUT), B.Sc. Engg. (IUT)

Mr. Md. Moshir Rahman Farazi  
M.Sc. Engg. (IUT), B.Sc. Engg. (IUT)

Mr. Ishtiza Ibne Azad  
M.Sc. Engg. (IUT), B.Sc. Engg. (IUT)

Mr. Iftekhar Hasan  
M.Sc. Engg. (IUT), B.Sc. Engg. (IUT)

Mr. Rifat Ahmed  
B.Sc. Engg. (IUT)

Mr. Mohammad Tanvirul Ferdaous  
M.Sc. Engg. (IUT), B.Sc. Engg. (IUT)

Mr. Md. Ghulam Saber  
M.Sc. Engg. (IUT), B.Sc. Engg. (IUT)

Mr. Minhaj Nur Alam  
M.Sc. Engg. (IUT), B.Sc. Engg. (IUT)

Mr. Safayat Bin Hakim  
M.Sc. Engg. (IUT), B.Sc. Engg. (IUT)

## **Part Time Faculty**

Prof. Dr. K. Siddique-e-Rabbani  
Department of Biomedical Physics and Technology, DU

Prof. Dr. Md. Wahab Khan  
Chemistry Department, BUET

Prof. Dr. Md. Monwarul Islam  
Chemistry Department, BUET

Prof. Dr. A. K. M. Akther Hossain  
Physics Department, BUET

Prof. Dr. Feroz Alam Khan  
Physics Department, BUET

Prof. Dr. Md. Aynal Haque  
EEE Department, BUET

Prof. Dr. Mohammad Anwarul Abedin  
EEE Department, DUET

Prof. Md. Obayed Ullah  
Mathematics Department, BUET

Mr. Md. Abdul Quddus Mian  
Former Associate Professor, Mathematics Department, BUET

Dr. Md. Rafi Uddin  
Associate Professor, Physics Department, BUET

Mr. Muhammad Hamidur Rahman  
Former Assistant Professor, EEE Department, BUET and IUT

Mr. Kazi Obaidul Awal  
Former Assistant Professor, EEE Department, IUT

Md. Abdus Sattar  
Associate Professor, CSE Department, BUET

Dr. Mohammed Forhad Uddin  
Professor, Mathematics Department, BUET

## **Staff Members**

Mr. Md. Ghulam Haider  
Senior Sub-divisional Engineer

Mr. Masudur Rahman Sarker  
Instrument Engineer

Mr. Engr. Muhammad Anowar Kabir  
Laboratory Instructor

Mr. Md. Golam Mostafa  
Assistant Laboratory Instructor

Mr. Md. Rasel Mia  
Assistant Laboratory Instructor

Mr. Md. Mozammel Hossain  
Assistant Laboratory Instructor

Mr. Md Ehsanul Islam  
Senior Operator

Mr. Faisal Ahmed  
Assistant Secretary

## **3.4 Study Programmes**

### **3.4.1 Undergraduate Programmes**

The programs are:

- Bachelor of Science in Electrical and Electronic Engineering
- Higher Diploma in Electrical and Electronic Engineering

The B.Sc. Engineering program in Electrical and Electronic Engineering comprises of four years of study consisting of eight consecutive semesters of

sixteen weeks duration each. However, there is a provision for award of Higher Diploma in Electrical and Electronic Engineering with specializations in Power System Technology and Computer Science and Engineering, after successful completion of three years (six semesters) of study. Higher Diploma in Engineering graduates may also continue further for completion of B.Sc. Engineering program.

The course curricula contain engineering science of high level as well as components for hands-on-experience to produce engineers of international standard having relevance to the development needs of the Member States. The course curricula are under constant scrutiny and review and continuously updated to meet the current needs and requirements. The levels and contents are always kept at international standard. The laboratory facilities are also upgraded from time to time to incorporate new ideas and technologies.

### **3.4.2 Postgraduate Programs**

The programs are:

- Doctor of Philosophy in Electrical and Electronic Engineering
- Master of Science in Electrical and Electronic Engineering
- Master of Electrical and Electronic Engineering

The Department offers two research degrees, Doctor of Philosophy (Ph.D.) and Master of Science (M.Sc.) in Electrical and Electronic Engineering. These higher degrees are awarded on the basis of prescribed course works and independent but supervised research in a topic, culminating in the submission of a thesis. For the M.Sc. degree, the period of candidature is normally 3 semesters requiring 18 credit hours of course work and 18 credit hours of research. Completion of the Ph.D. degree requires 54 credit hours and normally takes 6 semesters.

Master of Engineering in Electrical and Electronic Engineering is structured around course works and requires 30 credit hours of course work and 6 credit hours of research/projects. The period of candidature for this program is normally 3 semesters.

## **3.5 Labs and Facilities under Electrical and Electronic Department**

With a view to enabling the students to have hands on experience and to properly understand the applicability of theories taught in the class rooms, the following laboratories and workshops have been established:

- Electrical Machine Lab.
- Power Systems Lab.
- Electrical Utilization Lab.
- Electrical Workshop
- Switchgear and Protection Lab.
- Microprocessor and Micro-controller Systems Lab.
- Control System Lab.
- Digital Electronics Lab.
- Measurements and Instrumentation Lab.
- Electronics Lab.
- Electronic Workshop
- Industrial Electronics Lab.
- Microwave & Radio Engineering Lab
- Telecommunication Lab.
- Signal Processing Lab.
- VLSI Circuits Lab.
- Medical Electronics Lab.
- Physics Lab.

## **Chapter 4**

### **Detailed Course Information**

## 4.1 Course Structure for Undergraduate Programme

### 4.1.1 Course Credit Distribution Table

### 4.1.2 Course Designation and Numbering System

All departmental courses (course number starting with EEE) are numbered according to EEE departmental internal policy. According to that policy, each

| Category     | Description                         | Theory Credit | % (Theory credit) | Lab Credit   | Total Credit  |
|--------------|-------------------------------------|---------------|-------------------|--------------|---------------|
| A            | Arts, Humanities and Social Science | 22            | 15.71%            | 2.00         | 24            |
| B            | General Science and Mathematics     | 32            | 22.86%            | 4.50         | 36.50         |
| C            | Engineering Compulsory              | 62            | 44.29%            | 32.50        | 94.50         |
| D            | Engineering Optional                | 24            | 17.14%            | 3.00         | 27            |
| <b>Total</b> |                                     | <b>140</b>    | <b>100%</b>       | <b>42.00</b> | <b>182.00</b> |

course contains four digits WXYZ in a course code EEE WXYZ. The first digit W indicates program year. For a 4-year program such as B.Sc. Engineering, the first digit is 4, e.g., course code is EEE 4XYZ. The second digit X represents semester (1 to 8). For example, a course in third semester of a four year program will be EEE 43YZ. Third and fourth digits YZ represent type of course as follows:

| 3 <sup>rd</sup> and 4 <sup>th</sup> digit (YZ) | Meaning   | 3 <sup>rd</sup> digit (Y)          |
|--|---|------------------------------------|
| 01 to 19                                       | Compulsory courses  | 0 or 1                             |
| 20 to 39                                       | Power electives   | 2 or 3                             |
| 40 to 59                                       | Communication electives   | 4 or 5                             |
| 60 to 79                                       | All other electives   | 6 or 7                             |
| 80 to 99                                       | Courses offered to other departments and industrial training (90) | 8 or 9<br>(9 for TVE, 8 for other) |

Odd fourth digit Z represents theory course and even fourth digit Z represents sessional course. Fourth digit Z for EEE theory courses to other departments is 1 for MCE, 3 for CSE, 5 for CEE. The numbering policy can be summarized in the following figure:

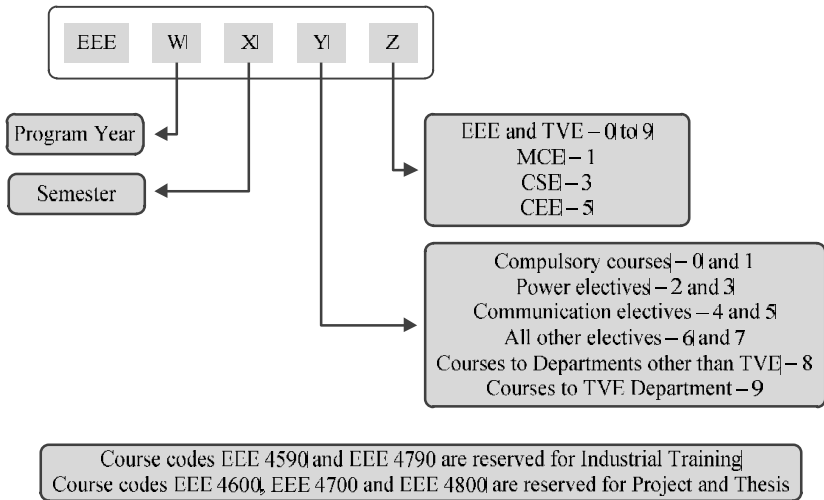

The course numbering system for the general courses like Mathematics, Physics, Chemistry, Humanities etc. is depicted in the following figure -

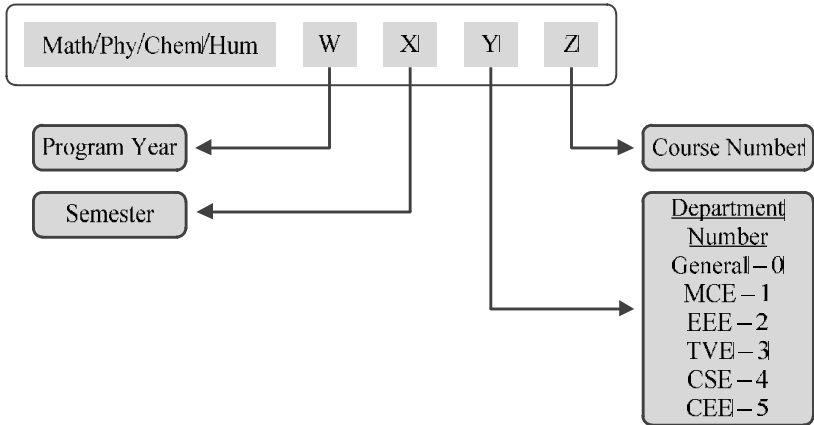

Odd fourth digit Z represents theory course and even fourth digit Z represents sessional course.



### 4.1.3 Category-wise Course Structure

#### A. Arts, Humanities and Social Science

| Course Code                                  | Course Title                            | Type of Course | Contact Hours | Credit Hours |
|--|---|----------------|---------------|--------------|
| Hum 4122/<br>Hum 4124                        | Arabic I/<br>English I                  | Practical      | 2             | 1.00         |
| Hum 4125                                     | Islamic Philosophy, History and Culture | Theory         | 3             | 3.00         |
| Hum 4222/<br>Hum 4224                        | Arabic II/<br>English II                | Practical      | 2             | 1.00         |
| Hum 4225                                     | Professional Ethics and Legal Issues    | Theory         | 3             | 3.00         |
| Hum 4421                                     | Science, Technology and Islam           | Theory         | 2             | 2.00         |
| Hum 4521                                     | Engineering Management                  | Theory         | 3             | 3.00         |
| Hum 4621                                     | Technology, Environment and Society     | Theory         | 3             | 3.00         |
| Hum 4721                                     | Engineering Economics                   | Theory         | 2             | 2.00         |
| Hum 4821                                     | Business Communication Skill            | Theory         | 3             | 3.00         |
| Hum 4823                                     | Sociology and Financial Accounting      | Theory         | 3             | 3.00         |
| <b>Contact Hours: 26 Credit Hours: 24.00</b> |   |                |               |              |

## B. General Science and Mathematics

| Course Code                                  | Course Title   | Type of Course | Contact Hours | Credit Hours |
|--|--|----------------|---------------|--------------|
| Math 4121                                    | Mathematics I (Calculus and Geometry)                              | Theory         | 3             | 3.00         |
| Math 4123                                    | Mathematics II (Matrices and Differential Equations)               | Theory         | 3             | 3.00         |
| Math 4221                                    | Mathematics III (Complex Variable, Vector Analysis and Statistics) | Theory         | 3             | 3.00         |
| Math 4321                                    | Mathematics IV (Transform Techniques and Linear Algebra)           | Theory         | 3             | 3.00         |
| Math 4421                                    | Random Signals and Processes                                       | Theory         | 3             | 3.00         |
| Math 4422                                    | Random Signals and Processes Lab.                                  | Practical      | 3/2           | 0.75         |
| Math 4521                                    | Numerical Methods  | Theory         | 3             | 3.00         |
| Math 4522                                    | Numerical Methods Lab.   | Practical      | 3/2           | 1.50         |
| Phy 4121                                     | Engineering Physics I  | Theory         | 3             | 3.00         |
| Phy 4122                                     | Engineering Physics I Lab.   | Practical      | 3/2           | 0.75         |
| Phy 4221                                     | Engineering Physics II   | Theory         | 3             | 3.00         |
| Phy 4222                                     | Engineering Physics II Lab.  | Practical      | 3/2           | 0.75         |
| Phy 4421                                     | Semiconductor Devices  | Theory         | 3             | 3.00         |
| Phy 4821                                     | Engineering Materials  | Theory         | 2             | 2.00         |
| Chem 4121                                    | Engineering Chemistry  | Theory         | 3             | 3.00         |
| Chem 4122                                    | Engineering Chemistry Lab.   | Practical      | 3/2           | 0.75         |
| <b>Contact Hours: 26 Credit Hours: 24.00</b> |  |                |               |              |

## C. Engineering Compulsory

### Group 1: Electrical Engineering General

| Course Code  | Course Title               | Type of Course | Contact Hours | Credit Hours |
|--|----------------------------|----------------|---------------|--------------|
| EEE 4101   | Electrical Circuit I       | Theory         | 3             | 3.00         |
| EEE 4102   | Electrical Circuit I Lab.  | Practical      | 3             | 1.50         |
| EEE 4201   | Electrical Circuit II      | Theory         | 3             | 3.00         |
| EEE 4202   | Electrical Circuit II Lab. | Practical      | 3             | 1.50         |
| EEE 4416   | Simulation Lab.            | Practical      | 2             | 1.00         |
| EEE 4590   | Industrial Training*       |                |               | 1.00         |
| EEE 4600   | Project and Design*        | Practical      | 6             | 3.00         |
| EEE 4790   | Industrial Training**      |                |               | 1.00         |
| EEE 4700   | Project and Thesis**       | Practical      | 6             | 3.00         |
| EEE 4800   | Project and Thesis**       | Practical      | 6             | 3.00         |
| <b>(For HDEE) Contact Hours: 20 Credit Hours: 14.00</b>        |                            |                |               |              |
| <b>(For B.Sc. Engg.) Contact Hours: 26 Credit Hours: 17.00</b> |                            |                |               |              |

\*For HDEE students

\*\*For B.Sc. Engg. (EEE). Students

## Group 2: Power Systems

| Course Code                                  | Course Title               | Type of Course | Contact Hours | Credit Hours |
|--|----------------------------|----------------|---------------|--------------|
| EEE 4418                                     | Electrical Services Design | Practical      | 2             | 1.00         |
| EEE 4301                                     | Power System I             | Theory         | 3             | 3.00         |
| EEE 4302                                     | Power System I Lab.        | Practical      | 3/2           | 0.75         |
| EEE 4305                                     | Energy Conversion I        | Theory         | 3             | 3.00         |
| EEE 4306                                     | Energy Conversion I Lab.   | Practical      | 3/2           | 0.75         |
| EEE 4401                                     | Power System II            | Theory         | 3             | 3.00         |
| EEE 4402                                     | Power System II Lab.       | Practical      | 3/2           | 0.75         |
| EEE 4405                                     | Energy Conversion II       | Theory         | 3             | 3.00         |
| EEE 4406                                     | Energy Conversion II Lab.  | Practical      | 3/2           | 0.75         |
| EEE 4801                                     | Power Generation           | Theory         | 3             | 3.00         |
| <b>Contact Hours: 23 Credit Hours: 19.00</b> |                            |                |               |              |

### Group 3: Communication

| Course Code                                  | Course Title                      | Type of Course | Contact Hours | Credit Hours |
|--|-----------------------------------|----------------|---------------|--------------|
| EEE 4403                                     | Communication Engineering I       | Theory         | 3             | 3.00         |
| EEE 4403                                     | Communication Engineering I Lab.  | Practical      | 3/2           | 0.75         |
| EEE 4501                                     | Electromagnetic Fields and Waves  | Theory         | 3             | 3.00         |
| EEE 4703                                     | Communication Engineering II      | Theory         | 3             | 3.00         |
| EEE 4703                                     | Communication Engineering II Lab. | Practical      | 3/2           | 0.75         |
| <b>Contact Hours: 12 Credit Hours: 10.50</b> |                                   |                |               |              |

### Group 4: Electronics

| Course Code                                  | Course Title             | Type of Course | Contact Hours | Credit Hours |
|--|--------------------------|----------------|---------------|--------------|
| EEE 4203                                     | Electronics I            | Theory         | 3             | 3.00         |
| EEE 4203                                     | Electronics I lab.       | Practical      | 3             | 1.50         |
| EEE 4303                                     | Electronics II           | Theory         | 3             | 3.00         |
| EEE 4303                                     | Electronics II Lab.      | Practical      | 3             | 1.50         |
| EEE 4307                                     | Digital Electronics      | Theory         | 3             | 3.00         |
| EEE 4308                                     | Digital Electronics lab. | Practical      | 3             | 1.50         |
| EEE 4503                                     | Power Electronics        | Theory         | 3             | 3.00         |
| EEE 4504                                     | Power Electronics lab.   | Practical      | 3             | 1.50         |
| <b>Contact Hours: 24 Credit Hours: 18.00</b> |                          |                |               |              |

**Group 5: Signal Processing and Interdisciplinary**

| <b>Course Code</b>                             | <b>Course Title</b>                                   | <b>Type of Course</b> | <b>Contact Hours</b> | <b>Credit Hours</b> |
|--|---|-----------------------|----------------------|---------------------|
| EEE 4516                                       | Microprocessor and Assembly Language Programming Lab. | Practical             | 3                    | 1.50                |
| EEE 4518                                       | Electrical and Electronic Workshop                    | Practical             | 2                    | 1.00                |
| EEE 4601                                       | Signals and Systems                                   | Theory                | 3                    | 3.00                |
| EEE 4602                                       | Signals and Systems Lab.                              | Practical             | 3/2                  | 0.75                |
| EEE 4603                                       | Measurement and Instrumentation                       | Theory                | 3                    | 3.00                |
| EEE 4604                                       | Measurement and Instrumentation Lab.                  | Practical             | 3/2                  | 0.75                |
| EEE 4605                                       | Microcontroller Based System Design                   | Theory                | 3                    | 3.00                |
| EEE 4606                                       | Microcontroller Based System Design Lab.              | Practical             | 3/2                  | 0.75                |
| EEE 4701                                       | Digital Signal Processing I                           | Theory                | 3                    | 3.00                |
| EEE 4702                                       | Digital Signal Processing I Lab.                      | Practical             | 3/2                  | 0.75                |
| EEE 4705                                       | Control System Engineering I                          | Theory                | 3                    | 3.00                |
| EEE 4706                                       | Control System Engineering I Lab.                     | Practical             | 3/2                  | 0.75                |
| <b>Contact Hours: 27.5 Credit Hours: 21.25</b> |   |                       |                      |                     |

**Group 6: Inter-departmental**

| <b>Course Code</b>                            | <b>Course Title</b>               | <b>Type of Course</b> | <b>Contact Hours</b> | <b>Credit Hours</b> |
|---|-----------------------------------|-----------------------|----------------------|---------------------|
| MCE 4192                                      | Mechanical Engineering Drawing    | Practical             | 3/2                  | 0.75                |
| MCE 4391                                      | Basic Mechanical Engineering      | Theory                | 3                    | 3.00                |
| MCE 4392                                      | Basic Mechanical Engineering Lab. | Practical             | 3/2                  | 0.75                |
| CSE 4271                                      | Computer Programming              | Theory                | 2                    | 2.00                |
| CSE 4272                                      | Computer Programming Lab.         | Practical             | 3                    | 1.50                |
| CEE 4106                                      | Civil Engineering Drawing         | Practical             | 3/2                  | 0.75                |
| <b>Contact Hours: 12.5 Credit Hours: 8.75</b> |                                   |                       |                      |                     |

### D. Engineering Optional

| <b>Power Systems Group</b>       |   |                       |                      |                     |
|----------------------------------|---|-----------------------|----------------------|---------------------|
| <b>Courses with Sessional</b>    |   |                       |                      |                     |
| <b>Course Code</b>               | <b>Course Title</b>                             | <b>Type of Course</b> | <b>Contact Hours</b> | <b>Credit Hours</b> |
| EEE 4521                         | Power System Protection                         | Theory                | 3                    | 3.00                |
| EEE 4522                         | Power System Protection Lab.                    | Practical             | 3/2                  | 0.75                |
| EEE 4523                         | Switchgear and Control Equipment I              | Theory                | 3                    | 3.00                |
| EEE 4524                         | Switchgear and Control Equipment I Lab.         | Practical             | 3/2                  | 0.75                |
| EEE 4621                         | Electrical Installations                        | Theory                | 3                    | 3.00                |
| EEE 4622                         | Electrical Installations Lab.                   | Practical             | 3/2                  | 0.75                |
| EEE 4623                         | Switchgear and Control Equipment II             | Theory                | 3                    | 3.00                |
| EEE 4624                         | Switchgear and Control Equipment II Lab.        | Practical             | 3/2                  | 0.75                |
| EEE 4625                         | Utilization of Electrical Energy                | Theory                | 3                    | 3.00                |
| EEE 4626                         | Utilization of Electrical Energy Lab.           | Practical             | 3/2                  | 0.75                |
| EEE 4721                         | Advanced Power System Protection                | Theory                | 3                    | 3.00                |
| EEE 4722                         | Advanced Power System Protection Lab.           | Practical             | 3/2                  | 0.75                |
| EEE 4723                         | Computer Methods in Electric Power Systems      | Theory                | 3                    | 3.00                |
| EEE 4724                         | Computer Methods in Electric Power Systems Lab. | Practical             | 3/2                  | 0.75                |
| <b>Courses without Sessional</b> |   |                       |                      |                     |
| <b>Course Code</b>               | <b>Course Title</b>                             | <b>Type of Course</b> | <b>Contact Hours</b> | <b>Credit Hours</b> |
| EEE 4531                         | Energy Conversion III                           | Theory                | 3                    | 3.00                |
| EEE 4533                         | High Voltage Engineering                        | Theory                | 3                    | 3.00                |
| EEE 4631                         | Renewable Energy System                         | Theory                | 3                    | 3.00                |
| EEE 4633                         | Nuclear Power Engineering                       | Theory                | 3                    | 3.00                |
| EEE 4635                         | Power Plant Engineering and                     | Theory                | 3                    | 3.00                |



|          |                                    |        |   |      |
|----------|------------------------------------|--------|---|------|
|          | Economy                            |        |   |      |
| EEE 4637 | Smart Grid                         | Theory | 3 | 3.00 |
| EEE 4731 | Power System III                   | Theory | 3 | 3.00 |
| EEE 4831 | Advanced Electrical Machines       | Theory | 3 | 3.00 |
| EEE 4833 | HVDC Power Transmission            | Theory | 3 | 3.00 |
| EEE 4835 | Power System Operation and Control | Theory | 3 | 3.00 |

| <b>Communication Group</b>       |                                      |                       |                      |                     |
|----------------------------------|--------------------------------------|-----------------------|----------------------|---------------------|
| <b>Courses with Sessional</b>    |                                      |                       |                      |                     |
| <b>Course Code</b>               | <b>Course Title</b>                  | <b>Type of Course</b> | <b>Contact Hours</b> | <b>Credit Hours</b> |
| EEE 4541                         | Wireless Communication               | Theory                | 3                    | 3.00                |
| EEE 4542                         | Wireless Communication Lab.          | Practical             | 3/2                  | 0.75                |
| EEE 4641                         | Cellular Communication               | Theory                | 3                    | 3.00                |
| EEE 4642                         | Cellular Communication Lab.          | Practical             | 3/2                  | 0.75                |
| EEE 4741                         | Optical Communication                | Theory                | 3                    | 3.00                |
| EEE 4742                         | Optical Communication Lab.           | Practical             | 3/2                  | 0.75                |
| EEE 4841                         | Microwave Engineering                | Theory                | 3                    | 3.00                |
| EEE 4842                         | Microwave Engineering Lab.           | Practical             | 3/2                  | 0.75                |
| <b>Courses without Sessional</b> |                                      |                       |                      |                     |
| <b>Course Code</b>               | <b>Course Title</b>                  | <b>Type of Course</b> | <b>Contact Hours</b> | <b>Credit Hours</b> |
| EEE 4551                         | Data Communication and Networking I  | Theory                | 3                    | 3.00                |
| EEE 4553                         | Information and Coding theory        | Theory                | 3                    | 3.00                |
| EEE 4651                         | Data Communication and Networking II | Theory                | 3                    | 3.00                |
| EEE 4751                         | Satellite and Radar System           | Theory                | 3                    | 3.00                |
| EEE 4851                         | Advanced Communication Technique     | Theory                | 3                    | 3.00                |

| <b>Electronics Group</b>         |  |                       |                      |                     |
|----------------------------------|--|-----------------------|----------------------|---------------------|
| <b>Courses with Sessional</b>    |  |                       |                      |                     |
| <b>Course Code</b>               | <b>Course Title</b>                              | <b>Type of Course</b> | <b>Contact Hours</b> | <b>Credit Hours</b> |
| EEE 4661                         | Analog Filter Design                             | Theory                | 3                    | 3.00                |
| EEE 4662                         | Analog Filter Design Lab.                        | Practical             | 3/2                  | 0.75                |
| EEE 4761                         | VLSI Circuits I                                  | Theory                | 3                    | 3.00                |
| EEE 4762                         | VLSI Circuits I Lab.                             | Practical             | 3/2                  | 0.75                |
| EEE 4763                         | Medical Electronics                              | Theory                | 3                    | 3.00                |
| EEE 4764                         | Medical Electronics Lab.                         | Practical             | 3/2                  | 0.75                |
| EEE 4765                         | Embedded System Design                           | Theory                | 3                    | 3.00                |
| EEE 4766                         | Embedded System Design Lab.                      | Practical             | 3/2                  | 0.75                |
| EEE 4861                         | VLSI Circuits II                                 | Theory                | 3                    | 3.00                |
| EEE 4862                         | VLSI Circuits II Lab.                            | Practical             | 3/2                  | 0.75                |
| EEE 4863                         | Bio Instrumentation                              | Theory                | 3                    | 3.00                |
| EEE 4864                         | Bio Instrumentation Lab.                         | Practical             | 3/2                  | 0.75                |
| EEE 4865                         | Digital Filter Design                            | Theory                | 3                    | 3.00                |
| EEE 4866                         | Digital Filter Design Lab.                       | Practical             | 3/2                  | 0.75                |
| <b>Courses without Sessional</b> |  |                       |                      |                     |
| <b>Course Code</b>               | <b>Course Title</b>                              | <b>Type of Course</b> | <b>Contact Hours</b> | <b>Credit Hours</b> |
| EEE 4571                         | Optoelectronics                                  | Theory                | 3                    | 3.00                |
| EEE 4573                         | Analog Integrated Electronics                    | Theory                | 3                    | 3.00                |
| EEE 4575                         | Illumination Engineering                         | Theory                | 3                    | 3.00                |
| EEE 4771                         | Compound Semiconductor and Heterojunction Device | Theory                | 3                    | 3.00                |

| <b>Signal Processing and Interdisciplinary Group</b> |   |                       |                      |                     |
|--|---|-----------------------|----------------------|---------------------|
| <b>Courses with Sessional</b>                        |   |                       |                      |                     |
| <b>Course Code</b>                                   | <b>Course Title</b>                             | <b>Type of Course</b> | <b>Contact Hours</b> | <b>Credit Hours</b> |
| EEE 4867   | Microprocessor System Design                    | Theory                | 3                    | 3.00                |
| EEE 4868   | Microprocessor System Design Lab.               | Practical             | 3/2                  | 0.75                |
| EEE 4869   | Digital Signal Processing II                    | Theory                | 3                    | 3.00                |
| EEE 4870   | Digital Signal Processing II Lab.               | Practical             | 3/2                  | 0.75                |
| EEE 4871   | Biomedical Signal Processing                    | Theory                | 3                    | 3.00                |
| EEE 4872   | Biomedical Signal Processing Lab.               | Practical             | 3/2                  | 0.75                |
| EEE 4873   | Control System Engineering II                   | Theory                | 3                    | 3.00                |
| EEE 4874   | Control System Engineering II Lab.              | Practical             | 3/2                  | 0.75                |
| EEE 4875   | Digital Image Processing                        | Theory                | 3                    | 3.00                |
| EEE 4876   | Digital Image Processing Lab.                   | Practical             | 3/2                  | 0.75                |
| CSE 4575   | Data Structures and Algorithm                   | Theory                | 3                    | 3.00                |
| CSE 4576   | Data Structures and Algorithm Lab.              | Practical             | 3/2                  | 0.75                |
| CSE 4679   | Operating System and System Programming         | Theory                | 3                    | 3.00                |
| CSE 4680   | Operating System and System Programming Lab.    | Practical             | 3/2                  | 0.75                |
| CSE 4681   | Database Management and Information System      | Theory                | 3                    | 3.00                |
| CSE 4682   | Database Management and Information System Lab. | Practical             | 3/2                  | 0.75                |
| CSE 4779   | System Analysis and Design                      | Theory                | 3                    | 3.00                |
| CSE 4780   | System Analysis and Design Lab.                 | Practical             | 3/2                  | 0.75                |
| CSE 4781   | Object Oriented Programming                     | Theory                | 3                    | 3.00                |
| CSE 4782   | Object Oriented Programming Lab.                | Practical             | 3/2                  | 0.75                |
| CSE 4871   | Software Development                            | Theory                | 3                    | 3.00                |

| CSE 4872                         | Software Development Lab.                    | Practical             | 3/2                  | 0.75                |
|----------------------------------|--|-----------------------|----------------------|---------------------|
| <b>Courses without Sessional</b> |  |                       |                      |                     |
| <b>Course Code</b>               | <b>Course Title</b>                          | <b>Type of Course</b> | <b>Contact Hours</b> | <b>Credit Hours</b> |
| EEE 4773                         | Artificial Neural Networks and Fuzzy Logic   | Theory                | 3                    | 3.00                |
| EEE 4775                         | Introduction to Robotics and Computer Vision | Theory                | 3                    | 3.00                |
| CSE 4591                         | Discrete Mathematics                         | Theory                | 3                    | 3.00                |

## 4.1.4 Semester-wise Course Structure

### First Semester

| Course Code                                  | Course Title   | Type of Course | Contact Hours | Credit Hours |
|--|--|----------------|---------------|--------------|
| Hum 4122/<br>Hum 4124                        | Arabic I/<br>English I                               | Practical      | 2             | 1.00         |
| Hum 4125                                     | Islamic Philosophy, History and Culture              | Theory         | 3             | 3.00         |
| Math 4121                                    | Mathematics I (Calculus and Geometry)                | Theory         | 3             | 3.00         |
| Math 4123                                    | Mathematics II (Matrices and Differential Equations) | Theory         | 3             | 3.00         |
| Phy 4121                                     | Engineering Physics I                                | Theory         | 3             | 3.00         |
| Phy 4122                                     | Engineering Physics I Lab.                           | Practical      | 3/2           | 0.75         |
| Chem 4121                                    | Engineering Chemistry                                | Theory         | 3             | 3.00         |
| Chem 4122                                    | Engineering Chemistry Lab.                           | Practical      | 3/2           | 0.75         |
| EEE 4101                                     | Electrical Circuit I                                 | Theory         | 3             | 3.00         |
| EEE 4102                                     | Electrical Circuit I Lab.                            | Practical      | 3             | 1.50         |
| MCE 4192                                     | Mechanical Engineering Drawing                       | Practical      | 3/2           | 0.75         |
| CEE 4106                                     | Civil Engineering Drawing                            | Practical      | 3/2           | 0.75         |
| <b>Contact Hours: 29 Credit Hours: 23.50</b> |  |                |               |              |

## Second Semester

| Course Code                                    | Course Title   | Type of Course | Contact Hours | Credit Hours |
|--|--|----------------|---------------|--------------|
| Hum 4222/<br>Hum 4224                          | Arabic II/<br>English II   | Practical      | 2             | 1.00         |
| Hum 4225                                       | Professional Ethics and Legal Issues                               | Theory         | 3             | 3.00         |
| Math 4221                                      | Mathematics III (Complex Variable, Vector Analysis and Statistics) | Theory         | 3             | 3.00         |
| Phy 4221                                       | Engineering Physics II   | Theory         | 3             | 3.00         |
| Phy 4222                                       | Engineering Physics II Lab.  | Practical      | 3/2           | 0.75         |
| EEE 4201                                       | Electrical Circuit II  | Theory         | 3             | 3.00         |
| EEE 4202                                       | Electrical Circuit II Lab.   | Practical      | 3             | 1.50         |
| EEE 4203                                       | Electronics I  | Theory         | 3             | 3.00         |
| EEE 4204                                       | Electronics I Lab.   | Practical      | 3             | 1.50         |
| CSE 4271                                       | Computer Programming   | Theory         | 2             | 2.00         |
| CSE 4272                                       | Computer Programming Lab.  | Practical      | 3             | 1.50         |
| <b>Contact Hours: 29.5 Credit Hours: 23.25</b> |  |                |               |              |

### Third Semester

| Course Code                                    | Course Title   | Type of Course | Contact Hours | Credit Hours |
|--|--|----------------|---------------|--------------|
| Math 4321                                      | Mathematics IV (Transform Techniques and Linear Algebra) | Theory         | 3             | 3.00         |
| EEE 4301                                       | Power System I   | Theory         | 3             | 3.00         |
| EEE 4302                                       | Power System I Lab.                                      | Practical      | 3/2           | 0.75         |
| EEE 4303                                       | Electronics II   | Theory         | 3             | 3.00         |
| EEE 4304                                       | Electronics II Lab.                                      | Practical      | 3             | 1.50         |
| EEE 4305                                       | Energy Conversion I                                      | Theory         | 3             | 3.00         |
| EEE 4306                                       | Energy Conversion I Lab.                                 | Practical      | 3/2           | 0.75         |
| EEE 4307                                       | Digital Electronics                                      | Theory         | 3             | 3.00         |
| EEE 4308                                       | Digital Electronics Lab.                                 | Practical      | 3             | 1.50         |
| MCE 4391                                       | Basic Mechanical Engineering                             | Theory         | 3             | 3.00         |
| MCE 4392                                       | Basic Mechanical Engineering Lab.                        | Practical      | 3/2           | 0.75         |
| <b>Contact Hours: 28.5 Credit Hours: 23.25</b> |  |                |               |              |

## Fourth Semester

| Course Code                                  | Course Title                      | Type of Course | Contact Hours | Credit Hours |
|--|-----------------------------------|----------------|---------------|--------------|
| Hum 4421                                     | Science, Technology and Islam     | Theory         | 2             | 2.00         |
| Math 4421                                    | Random Signals and Processes      | Theory         | 3             | 3.00         |
| Math 4422                                    | Random Signals and Processes Lab. | Practical      | 3/2           | 0.75         |
| Phy 4421                                     | Semiconductor Devices             | Theory         | 3             | 3.00         |
| EEE 4401                                     | Power System II                   | Theory         | 3             | 3.00         |
| EEE 4401                                     | Power System II Lab.              | Practical      | 3/2           | 0.75         |
| EEE 4403                                     | Communication Engineering         | Theory         | 3             | 3.00         |
| EEE 4404                                     | Communication Engineering I Lab.  | Practical      | 3/2           | 0.75         |
| EEE 4405                                     | Energy Conversion II              | Theory         | 3             | 3.00         |
| EEE 4406                                     | Energy Conversion II Lab.         | Practical      | 3/2           | 0.75         |
| EEE 4416                                     | Simulation Lab.                   | Practical      | 2             | 1.00         |
| EEE 4418                                     | Electrical Services Design        | Practical      | 2             | 1.00         |
| <b>Contact Hours: 27 Credit Hours: 22.00</b> |                                   |                |               |              |



## Fifth Semester

| Course Code  | Course Title  | Type of Course | Contact Hours | Credit Hours |
|--|---|----------------|---------------|--------------|
| Hum 4521   | Engineering Management                                | Theory         | 3             | 3.00         |
| Math 4521  | Numerical Methods                                     | Theory         | 3             | 3.00         |
| Math 4522  | Numerical Methods Lab.                                | Practical      | 3             | 1.50         |
| EEE 4501   | Electromagnetic Fields and Waves                      | Theory         | 3             | 3.00         |
| EEE 4503   | Power Electronics                                     | Theory         | 3             | 3.00         |
| EEE 4504   | Power Electronics Lab.                                | Practical      | 3             | 1.50         |
| EEE 4516   | Microprocessor and Assembly Language Programming Lab. | Practical      | 3             | 1.50         |
| EEE 4518   | Electrical and Electronic Workshop                    | Practical      | 2             | 1.00         |
| EEE 4590   | Industrial Training*                                  |                |               | 1.00         |
|  | Elective I (with Lab.) **                             |                | 3 - 3/2       | 3.75         |
|  | Elective II (without Lab.) **                         |                | 3             | 3.00         |
| <b>Contact Hours: 30.5 Credit Hours: 24.25/25.25</b> |   |                |               |              |

\* Industrial training programme will be organized by IUT during the session break in between 4<sup>th</sup> and 5<sup>th</sup> semesters and it is compulsory for all the students of HDEE. Duration of the training programme will be about four weeks.

\*\* Student will be required to select two specialization/elective courses, with Lab. and without Lab., from specialization/elective Group 'A' on the approval of the Head of the Department

## Sixth Semester

| Course Code   | Course Title                             | Type of Course | Contact Hours | Credit Hours |
|---|--|----------------|---------------|--------------|
| Hum 4621  | Technology, Environment and Society      | Theory         | 3             | 3.00         |
| EEE 4600  | Project and Design *                     | Practical      | 6             | 3.00         |
| EEE 4601  | Signals and Systems                      | Theory         | 3             | 3.00         |
| EEE 4602  | Signals and Systems Lab.                 | Practical      | 3/2           | 0.75         |
| EEE 4603  | Measurement and Instrumentation          | Theory         | 3             | 3.00         |
| EEE 4604  | Measurement and Instrumentation Lab.     | Practical      | 3/2           | 0.75         |
| EEE 4605  | Microcontroller Based System Design      | Theory         | 3             | 3.00         |
| EEE 4606  | Microcontroller Based System Design Lab. | Practical      | 3/2           | 0.75         |
|   | Elective I (with Lab.) **                |                | 3 - 3/2       | 3.75         |
|   | Elective II (without Lab.) **            |                | 3             | 3.00         |
| <b>Contact Hours: 24.00/30.00 Credit Hours: 21.00/24.00</b> |  |                |               |              |

\* Students who have opted for HDEE will have to take course EEE 4600.

\*\* Student will be required to select two specialization/elective courses with Lab. and without Lab., from specialization/elective Group 'B' on the approval of the Head of the Department.

## Seventh Semester

| Course Code                                  | Course Title                      | Type of Course | Contact Hours | Credit Hours |
|--|-----------------------------------|----------------|---------------|--------------|
| Hum 4721                                     | Engineering Economics             | Theory         | 3             | 3.00         |
| EEE 4700                                     | Project and Thesis                | Practical      | 6             | 3.00         |
| EEE 4701                                     | Digital Signal Processing I       | Theory         | 3             | 3.00         |
| EEE 4702                                     | Digital Signal Processing I Lab.  | Practical      | 3/2           | 0.75         |
| EEE 4703                                     | Communication Engineering II      | Theory         | 3             | 3.00         |
| EEE 4704                                     | Communication Engineering II Lab. | Practical      | 3/2           | 0.75         |
| EEE 4705                                     | Control System Engineering I      | Theory         | 3             | 3.00         |
| EEE 4705                                     | Control System Engineering I Lab. | Practical      | 3/2           | 0.75         |
| EEE 4790                                     | Industrial Training*              |                |               | 1.00         |
|  | Elective I (with Lab.) **         |                | 3 - 3/2       | 3.75         |
|  | Elective II (without Lab.) **     |                | 3             | 3.00         |
| <b>Contact Hours: 29 Credit Hours: 24.00</b> |                                   |                |               |              |

\* Industrial training programme will be organized by IUT during the session break in between 6th and 7th semesters and it is compulsory for all the students of B.Sc. Engg. (EEE). Duration of the training programme will be about four weeks.

\*\* Student will be required to select two specialization/elective courses, with Lab. and without Lab., from specialization/elective Group 'C' on the approval of the Head of the Department.

## Eighth Semester

| Course Code                                    | Course Title                       | Type of Course | Contact Hours | Credit Hours |
|--|------------------------------------|----------------|---------------|--------------|
| Hum 4821                                       | Business Communication Skill       | Theory         | 3             | 3.00         |
| Hum 4823                                       | Sociology and Financial Accounting | Theory         | 3             | 3.00         |
| Phy 4821                                       | Engineering Materials              | Theory         | 2             | 2.00         |
| EEE 4800                                       | Project and Thesis                 | Practical      | 6             | 3.00         |
| EEE 4801                                       | Power Generation                   | Theory         | 3             | 3.00         |
|  | Elective I (with Lab.) *           |                | 3 - 3/2       | 3.75         |
|  | Elective II (without Lab.) *       |                | 3             | 3.00         |
| <b>Contact Hours: 24.5 Credit Hours: 20.75</b> |                                    |                |               |              |

\*Student will be required to select two specialization/elective courses, with Lab. and without Lab., from specialization/elective Group 'D' on the approval of the Head of the Department.

## 4.1.5 Semester-wise Elective Course Structure

Elective Courses to be offered in the 5<sup>th</sup>, 6<sup>th</sup>, 7<sup>th</sup>, 8<sup>th</sup> Semesters. On the advice of Head of the Department, students will be allowed to take two courses from Groups 'A', 'B', 'C', and 'D' accordingly as listed below:

### Group – 'A' (5<sup>th</sup> Semester Elective Courses)

| <b>Power Systems Group</b>  |   |                       |                      |                     |
|-----------------------------|---|-----------------------|----------------------|---------------------|
| <b>Courses with Lab.</b>    |   |                       |                      |                     |
| <b>Course Code</b>          | <b>Course Title</b>                     | <b>Type of Course</b> | <b>Contact Hours</b> | <b>Credit Hours</b> |
| EEE 4521                    | Power System Protection                 | Theory                | 3                    | 3.00                |
| EEE 4522                    | Power System Protection Lab.            | Practical             | 3/2                  | 0.75                |
| EEE 4523                    | Switchgear and Control Equipment I      | Theory                | 3                    | 3.00                |
| EEE 4524                    | Switchgear and Control Equipment I Lab. | Practical             | 3/2                  | 0.75                |
| <b>Courses without Lab.</b> |   |                       |                      |                     |
| <b>Course Code</b>          | <b>Course Title</b>                     | <b>Type of Course</b> | <b>Contact Hours</b> | <b>Credit Hours</b> |
| EEE 4531                    | Energy Conversion III                   | Theory                | 3                    | 3.00                |
| EEE 4533                    | High Voltage Engineering                | Theory                | 3                    | 3.00                |



| <b>Communication Group</b>  |                                     |                       |                      |                     |
|-----------------------------|-------------------------------------|-----------------------|----------------------|---------------------|
| <b>Courses with Lab.</b>    |                                     |                       |                      |                     |
| <b>Course Code</b>          | <b>Course Title</b>                 | <b>Type of Course</b> | <b>Contact Hours</b> | <b>Credit Hours</b> |
| EEE 4541                    | Wireless Communication              | Theory                | 3                    | 3.00                |
| EEE 4522                    | Wireless Communication Lab.         | Practical             | 3/2                  | 0.75                |
| <b>Courses without Lab.</b> |                                     |                       |                      |                     |
| <b>Course Code</b>          | <b>Course Title</b>                 | <b>Type of Course</b> | <b>Contact Hours</b> | <b>Credit Hours</b> |
| EEE 4551                    | Data Communication and Networking I | Theory                | 3                    | 3.00                |
| EEE 4553                    | Information and Coding Theory       | Theory                | 3                    | 3.00                |

| <b>Electronics Group</b>    |                               |                       |                      |                     |
|-----------------------------|-------------------------------|-----------------------|----------------------|---------------------|
| <b>Courses without Lab.</b> |                               |                       |                      |                     |
| <b>Course Code</b>          | <b>Course Title</b>           | <b>Type of Course</b> | <b>Contact Hours</b> | <b>Credit Hours</b> |
| EEE 4571                    | Optoelectronics               | Theory                | 3                    | 3.00                |
| EEE 4573                    | Analog Integrated Electronics | Theory                | 3                    | 3.00                |
| EEE 4575                    | Illumination Engineering      | Theory                | 3                    | 3.00                |

**Signal Processing and Interdisciplinary Group**

**Courses with Lab.**

| <b>Course Code</b> | <b>Course Title</b>                 | <b>Type of Course</b> | <b>Contact Hours</b> | <b>Credit Hours</b> |
|--------------------|-------------------------------------|-----------------------|----------------------|---------------------|
| CSE 4575           | Data Structures and Algorithms      | Theory                | 3                    | 3.00                |
| CSE 4576           | Data Structures and Algorithms Lab. | Practical             | 3/2                  | 0.75                |

**Courses without Lab.**

| <b>Course Code</b> | <b>Course Title</b>  | <b>Type of Course</b> | <b>Contact Hours</b> | <b>Credit Hours</b> |
|--------------------|----------------------|-----------------------|----------------------|---------------------|
| CSE 4591           | Discrete Mathematics | Theory                | 3                    | 3.00                |

**Group – ‘B’ (6<sup>th</sup> Semester Elective Courses)**

| <b>Power Systems Group</b>  |  |                       |                      |                     |
|-----------------------------|--|-----------------------|----------------------|---------------------|
| <b>Courses with Lab.</b>    |  |                       |                      |                     |
| <b>Course Code</b>          | <b>Course Title</b>                      | <b>Type of Course</b> | <b>Contact Hours</b> | <b>Credit Hours</b> |
| EEE 4621                    | Electrical Installations                 | Theory                | 3                    | 3.00                |
| EEE 4622                    | Electrical Installations Lab.            | Practical             | 3/2                  | 0.75                |
| EEE 4623                    | Switchgear and Control Equipment II      | Theory                | 3                    | 3.00                |
| EEE 4624                    | Switchgear and Control Equipment II Lab. | Practical             | 3/2                  | 0.75                |
| EEE 4625                    | Utilization of Electrical Energy         | Theory                | 3                    | 3.00                |
| EEE 4626                    | Utilization of Electrical Energy Lab.    | Practical             | 3/2                  | 0.75                |
| <b>Courses without Lab.</b> |  |                       |                      |                     |
| <b>Course Code</b>          | <b>Course Title</b>                      | <b>Type of Course</b> | <b>Contact Hours</b> | <b>Credit Hours</b> |
| EEE 4631                    | Renewable Energy System                  | Theory                | 3                    | 3.00                |
| EEE 4633                    | Nuclear Power Engineering                | Theory                | 3                    | 3.00                |
| EEE 4635                    | Power Plant Engineering and              | Theory                | 3                    | 3.00                |

|          |            |        |   |      |
|----------|------------|--------|---|------|
|          | Economy    |        |   |      |
| EEE 4637 | Smart Grid | Theory | 3 | 3.00 |

| <b>Communication Group</b>  |                                      |                       |                      |                     |
|-----------------------------|--------------------------------------|-----------------------|----------------------|---------------------|
| <b>Courses with Lab.</b>    |                                      |                       |                      |                     |
| <b>Course Code</b>          | <b>Course Title</b>                  | <b>Type of Course</b> | <b>Contact Hours</b> | <b>Credit Hours</b> |
| EEE 4641                    | Cellular Communication               | Theory                | 3                    | 3.00                |
| EEE 4642                    | Cellular Communication Lab.          | Practical             | 3/2                  | 0.75                |
| <b>Courses without Lab.</b> |                                      |                       |                      |                     |
| <b>Course Code</b>          | <b>Course Title</b>                  | <b>Type of Course</b> | <b>Contact Hours</b> | <b>Credit Hours</b> |
| EEE 4651                    | Data Communication and Networking II | Theory                | 3                    | 3.00                |

| <b>Electronics Group</b> |                     |                |                |               |
|--------------------------|---------------------|----------------|----------------|---------------|
| <b>Courses with Lab.</b> |                     |                |                |               |
| <b>Course Code</b>       | <b>Course Title</b> | <b>Type of</b> | <b>Contact</b> | <b>Credit</b> |

|          |                           | <b>Course</b> | <b>Hours</b> | <b>Hours</b> |
|----------|---------------------------|---------------|--------------|--------------|
| EEE 4661 | Analog Filter Design      | Theory        | 3            | 3.00         |
| EEE 4662 | Analog Filter Design Lab. | Practical     | 3/2          | 0.75         |

| <b>Signal Processing and Interdisciplinary Group</b> |   |                       |                      |                     |
|--|---|-----------------------|----------------------|---------------------|
| <b>Courses with Lab.</b>                             |   |                       |                      |                     |
| <b>Course Code</b>                                   | <b>Course Title</b>                             | <b>Type of Course</b> | <b>Contact Hours</b> | <b>Credit Hours</b> |
| CSE 4679   | Operating Systems and System Programming        | Theory                | 3                    | 3.00                |
| CSE 4680   | Operating Systems and System Programming Lab.   | Practical             | 3/2                  | 0.75                |
| CSE 4681   | Database Management and Information System      | Theory                | 3                    | 3.00                |
| CSE 4682   | Database Management and Information System Lab. | Practical             | 3/2                  | 0.75                |

**Group – ‘C’ (7<sup>th</sup> Semester Elective Courses)**

| <b>Power Systems Group</b>  |   |                       |                      |                     |
|-----------------------------|---|-----------------------|----------------------|---------------------|
| <b>Courses with Lab.</b>    |   |                       |                      |                     |
| <b>Course Code</b>          | <b>Course Title</b>                             | <b>Type of Course</b> | <b>Contact Hours</b> | <b>Credit Hours</b> |
| EEE 4721                    | Advanced Power System Protection                | Theory                | 3                    | 3.00                |
| EEE 4722                    | Advanced Power System Protection Lab.           | Practical             | 3/2                  | 0.75                |
| EEE 4723                    | Computer Methods in Electric Power Systems      | Theory                | 3                    | 3.00                |
| EEE 4724                    | Computer Methods in Electric Power Systems Lab. | Practical             | 3/2                  | 0.75                |
| <b>Courses without Lab.</b> |   |                       |                      |                     |
| <b>Course Code</b>          | <b>Course Title</b>                             | <b>Type of Course</b> | <b>Contact Hours</b> | <b>Credit Hours</b> |
| EEE 4731                    | Power System III                                | Theory                | 3                    | 3.00                |

| <b>Communication Group</b>  |                            |                       |                      |                     |
|-----------------------------|----------------------------|-----------------------|----------------------|---------------------|
| <b>Courses with Lab.</b>    |                            |                       |                      |                     |
| <b>Course Code</b>          | <b>Course Title</b>        | <b>Type of Course</b> | <b>Contact Hours</b> | <b>Credit Hours</b> |
| EEE 4741                    | Optical Communication      | Theory                | 3                    | 3.00                |
| EEE 4741                    | Optical Communication Lab. | Practical             | 3/2                  | 0.75                |
| <b>Courses without Lab.</b> |                            |                       |                      |                     |
| <b>Course Code</b>          | <b>Course Title</b>        | <b>Type of Course</b> | <b>Contact Hours</b> | <b>Credit Hours</b> |
| EEE 4751                    | Satellite and Radar System | Theory                | 3                    | 3.00                |



| <b>Electronics Group</b>    |  |                       |                      |                     |
|-----------------------------|--|-----------------------|----------------------|---------------------|
| <b>Courses with Lab.</b>    |  |                       |                      |                     |
| <b>Course Code</b>          | <b>Course Title</b>                              | <b>Type of Course</b> | <b>Contact Hours</b> | <b>Credit Hours</b> |
| EEE 4761                    | VLSI Circuits I                                  | Theory                | 3                    | 3.00                |
| EEE 4762                    | VLSI Circuits I Lab.                             | Practical             | 3/2                  | 0.75                |
| EEE 4763                    | Medical Electronics                              | Theory                | 3                    | 3.00                |
| EEE 4764                    | Medical Electronics Lab.                         | Practical             | 3/2                  | 0.75                |
| EEE 4765                    | Embedded System Design                           | Theory                | 3                    | 3.00                |
| EEE 4766                    | Embedded System Design Lab.                      | Practical             | 3/2                  | 0.75                |
| <b>Courses without Lab.</b> |  |                       |                      |                     |
| <b>Course Code</b>          | <b>Course Title</b>                              | <b>Type of Course</b> | <b>Contact Hours</b> | <b>Credit Hours</b> |
| EEE 4771                    | Compound Semiconductor and Heterojunction Device | Theory                | 3                    | 3.00                |

| <b>Signal Processing and Interdisciplinary Group</b> |  |                       |                      |                     |
|--|--|-----------------------|----------------------|---------------------|
| <b>Courses with Lab.</b>                             |  |                       |                      |                     |
| <b>Course Code</b>                                   | <b>Course Title</b>                          | <b>Type of Course</b> | <b>Contact Hours</b> | <b>Credit Hours</b> |
| CSE 4779   | System Analysis and Design                   | Theory                | 3                    | 3.00                |
| CSE 4780   | System Analysis and Design Lab.              | Practical             | 3/2                  | 0.75                |
| CSE 4781   | Object Oriented Programming                  | Theory                | 3                    | 3.00                |
| CSE 4782   | Object Oriented Programming Lab.             | Practical             | 3/2                  | 0.75                |
| <b>Courses without Lab.</b>                          |  |                       |                      |                     |
| <b>Course Code</b>                                   | <b>Course Title</b>                          | <b>Type of Course</b> | <b>Contact Hours</b> | <b>Credit Hours</b> |
| EEE 4773   | Artificial Neural Networks and Fuzzy Logic   | Theory                | 3                    | 3.00                |
| EEE 4775   | Introduction to Robotics and Computer Vision | Theory                | 3                    | 3.00                |

**Group – ‘D’ (8<sup>th</sup> Semester Elective Courses)**

| <b>Power Systems Group</b>  |                                    |                       |                      |                     |
|-----------------------------|------------------------------------|-----------------------|----------------------|---------------------|
| <b>Courses without Lab.</b> |                                    |                       |                      |                     |
| <b>Course Code</b>          | <b>Course Title</b>                | <b>Type of Course</b> | <b>Contact Hours</b> | <b>Credit Hours</b> |
| EEE 4831                    | Advanced Electrical Machines       | Theory                | 3                    | 3.00                |
| EEE 4833                    | HVDC Power Transmission            | Theory                | 3                    | 3.00                |
| EEE 4835                    | Power System Operation and Control | Theory                | 3                    | 3.00                |

| <b>Communication Group</b>  |                                   |                       |                      |                     |
|-----------------------------|-----------------------------------|-----------------------|----------------------|---------------------|
| <b>Courses with Lab.</b>    |                                   |                       |                      |                     |
| <b>Course Code</b>          | <b>Course Title</b>               | <b>Type of Course</b> | <b>Contact Hours</b> | <b>Credit Hours</b> |
| EEE 4841                    | Microwave Engineering             | Theory                | 3                    | 3.00                |
| EEE 4842                    | Microwave Engineering Lab.        | Practical             | 3/2                  | 0.75                |
| <b>Courses without Lab.</b> |                                   |                       |                      |                     |
| <b>Course Code</b>          | <b>Course Title</b>               | <b>Type of Course</b> | <b>Contact Hours</b> | <b>Credit Hours</b> |
| EEE 4851                    | Advanced Communication Techniques | Theory                | 3                    | 3.00                |

| <b>Electronics Group</b> |                            |                       |                      |                     |
|--------------------------|----------------------------|-----------------------|----------------------|---------------------|
| <b>Courses with Lab.</b> |                            |                       |                      |                     |
| <b>Course Code</b>       | <b>Course Title</b>        | <b>Type of Course</b> | <b>Contact Hours</b> | <b>Credit Hours</b> |
| EEE 4861                 | VLSI Circuits II           | Theory                | 3                    | 3.00                |
| EEE 4862                 | VLSI Circuits II Lab.      | Practical             | 3/2                  | 0.75                |
| EEE 4863                 | Bio Instrumentation        | Theory                | 3                    | 3.00                |
| EEE 4864                 | Bio Instrumentation Lab.   | Practical             | 3/2                  | 0.75                |
| EEE 4865                 | Digital Filter Design      | Theory                | 3                    | 3.00                |
| EEE 4866                 | Digital Filter Design Lab. | Practical             | 3/2                  | 0.75                |

**Signal Processing and Interdisciplinary Group****Courses with Lab.**

| <b>Course Code</b> | <b>Course Title</b>                | <b>Type of Course</b> | <b>Contact Hours</b> | <b>Credit Hours</b> |
|--------------------|------------------------------------|-----------------------|----------------------|---------------------|
| EEE 4867           | Microprocessor System Design       | Theory                | 3                    | 3.00                |
| EEE 4868           | Microprocessor System Design Lab.  | Practical             | 3/2                  | 0.75                |
| EEE 4869           | Digital Signal Processing II       | Theory                | 3                    | 3.00                |
| EEE 4870           | Digital Signal Processing II Lab.  | Practical             | 3/2                  | 0.75                |
| EEE 4871           | Biomedical Signal Processing       | Theory                | 3                    | 3.00                |
| EEE 4872           | Biomedical Signal Processing Lab.  | Practical             | 3/2                  | 0.75                |
| EEE 4873           | Control System Engineering II      | Theory                | 3                    | 3.00                |
| EEE 4874           | Control System Engineering II Lab. | Practical             | 3/2                  | 0.75                |
| EEE 4875           | Digital Image Processing           | Theory                | 3                    | 3.00                |
| EEE 4876           | Digital Image Processing Lab.      | Practical             | 3/2                  | 0.75                |
| CSE 4871           | Software Development               | Theory                | 3                    | 3.00                |
| CSE 4872           | Software Development Lab.          | Practical             | 3/2                  | 0.75                |

## 4.2 Course Structure for Post- Graduate Programme

| Course Number | Course Title   | Type of Course | Contact Hours | Credit Hours |
|---------------|--|----------------|---------------|--------------|
| EEE 6000      | Thesis   |                |               | 18.00        |
| EEE 6002      | Project  |                |               | 6.00         |
| EEE 6105      | Advanced Engineering Analysis                            | Theory         | 3             | 3.00         |
| EEE 6200      | Selected Topics in Electrical and Electronic Engineering | Theory         | 3             | 3.00         |
| EEE 6229      | VLSI Design  | Theory         | 3             | 3.00         |
| EEE 6231      | Advanced Analog IC Design                                | Theory         | 3             | 3.00         |
| EEE 6233      | Advanced Analog Electronics                              | Theory         | 3             | 3.00         |
| EEE 6235      | Advanced Solid State Devices                             | Theory         | 3             | 3.00         |
| EEE 6237      | IC Processing and Fabrication Technology                 | Theory         | 3             | 3.00         |
| EEE 6301      | Power System Reliability                                 | Theory         | 3             | 3.00         |
| EEE 6303      | Power System Planning                                    | Theory         | 3             | 3.00         |
| EEE 6305      | Transients in Power System                               | Theory         | 3             | 3.00         |
| EEE 6307      | Power System Modeling                                    | Theory         | 3             | 3.00         |
| EEE 6309      | Computer Methods in Power System Analysis                | Theory         | 3             | 3.00         |

|          |  |        |   |      |
|----------|--|--------|---|------|
| EEE 6311 | Power System Optimization                          | Theory | 3 | 3.00 |
| EEE 6401 | Optical Fiber Communication                        | Theory | 3 | 3.00 |
| EEE 6403 | Wireless Communication                             | Theory | 3 | 3.00 |
| EEE 6405 | Advanced Digital Signal Processing                 | Theory | 3 | 3.00 |
| EEE 6407 | Digital Communication                              | Theory | 3 | 3.00 |
| EEE 6409 | Information Theory                                 | Theory | 3 | 3.00 |
| EEE 6411 | Wireless Ad Hoc and Sensor Networks                | Theory | 3 | 3.00 |
| EEE 6413 | Engineering Optimization                           | Theory | 3 | 3.00 |
| EEE 6501 | Switching Theory                                   | Theory | 3 | 3.00 |
| EEE 6503 | Advanced Computer Architecture                     | Theory | 3 | 3.00 |
| EEE 6505 | Analysis and Design of Digital Integrated Circuits | Theory | 3 | 3.00 |
| EEE 6507 | CISC Microprocessor System Design                  | Theory | 3 | 3.00 |
| EEE 6601 | Antennas and Propagation                           | Theory | 3 | 3.00 |
| EEE 6603 | Microwave Devices and Circuits                     | Theory | 3 | 3.00 |
| EEE 6605 | Semiconductor Lasers                               | Theory | 3 | 3.00 |
| EEE 6607 | Computational Electromagnetics                     | Theory | 3 | 3.00 |
| EEE 6701 | Nonlinear Control System                           | Theory | 3 | 3.00 |
| EEE 6703 | Modern Control                                     | Theory | 3 | 3.00 |

|          |                        |        |   |      |
|----------|------------------------|--------|---|------|
| EEE 6705 | Digital Control System | Theory | 3 | 3.00 |
| EEE 6801 | Power Electronics      | Theory | 3 | 3.00 |



## **4.3 Course Syllabus**

### **4.3.1 Contents of Undergraduate Courses**

#### **4.3.1.1 Courses Offered by EEE Department to EEE Students**

##### **First Semester**

##### **Hum 4122 Arabic I**

**Credit 1.00**

Reading Comprehension; Letters and Pronunciation; Construction of words; Use of letters (Shamsi & Kamari) in words; Use of determiners and pronouns; Use of interrogatives; Use of nominal and verbal sentences Use of adverbs; Use of tenses; Use of Feminine & Masculine Genders; Use of Numerical; Conjunctive Adverbs; Conversation and dialogues in real life. Improvement of communication skill using audio-visual aid.

##### **Hum 4124 English I**

**Credit 1.00**

Listening & Speaking: Situational dialogues; Use of dialogues in conversations; Reading out, talks; Listening to prescribed cassettes; Watching documentaries. Reading: Reading comprehension; Reading for pleasure; Reading for understanding; Reading with strategies. Writing & Grammar: Word classes, sentence types; Number, person, gender; Tenses and sequences of tenses; Nouns and determiners; Operators; If-clauses; Paragraphs & letters; Text analysis. Vocabulary: In lists; Contextualized; In talks; In exercises.

**Hum 4125 Islamic Philosophy, History and Culture**

**Credit 3.00**

Islamic Philosophy: Islam as Din; Sources of Islamic Code of Life; Social, Economic and Political system of Islam; Islamic; Ethics: Human values in Islam, Dignity of Man, Women & Islam Family Ties, Moral values, Decency and Decorum, Brotherhood, Friendship and Amity in human society, Truthfulness, Honesty, Sincerity, Righteousness, Piety and Religiousness; Social vices; Role of Islam in eradicating social evils; Islam and Environment; Islam and the world peace.

Life and works of the Prophet Muhammad (SM). Caliphate of the pious caliphs. Islamic Culture & Islamic festivals; Islamic Arts and Crafts; Importance of acquiring knowledge of Science and Technology in the light of the Holy Quran and the Sunnah; Relation between Science & Technology and Islam; Scientific indications in the Holy Quran, Impact of Science, Technology and Religion on Society and Social Development. Contributions of Islamic Civilization and Scientific achievement on the development of modern Science and Technology.

**Math 4121 Mathematics I (Calculus and Geometry)**

**Credit 3.00**

Differential calculus: Limit, continuity and differentiability of functions. Successive differentiation. Leibnitz theorem. Taylor and Maclaurin theorem, expansion of functions in series. Indeterminate forms. Partial differentiation, tangent, normal, curvature, asymptotes, envelopes, curve tracing. Determination of maximum and minimum of functions with applications.

Integral Calculus: Integration by the method of substitution. Integration by parts. Integration by successive reduction. Standard integrals. Definite integrals, its properties and use in summing series. Determination of area under a plane curve and area of a region enclosed by two curves in Cartesian and polar co-ordinates. Trapezoidal and Simpson's rules. Arc length of a curve in Cartesian and polar co-ordinates. Volumes and surface areas of solids of revolution.

Two dimensional co-ordinate geometry: Change of axes. Transformation of co-ordinates. Simplifications of equation of curves.

**Math 4123 Mathematics II (Matrices and  
Differential Equations)**

**Credit 3.00**

Matrices: Definition of matrices. Algebra of matrices. Transpose of a matrix. Determinants. Inverse of a matrix, rank of matrix, elementary transformations. Factorization. Introduction to system of linear equations. Gaussian elimination. Quadratic forms. Matrix polynomials. Eigenvalues and Eigenvectors.

Ordinary differential equations: Definition, solution of first order differential equation, variable separable form, reducibility, exact differential equation, integrating factor. Solution of second order differential equations with constant co-efficient and their applications. Factorization of the operator, solution of simultaneous differential equation of first and second order with applications in electrical engineering problems. Solution of linear differential equations with variable Coefficients, series solution of differential equations. Partial differential equations: First and second order partial differential equation, Boundary value problems. Laplace equation and Poisson equation and their solution in rectangular and cylindrical co-ordinates. Eigen value and boundary value problems in electrical and electronic Engineering.

**Phy 4121 Engineering Physics I**

**Credit 3.00**

Atomic structure. Thompsons, Rutherford and Bhor's atomic model. Atomic arrangement in solids. Different types of bonds in solids- metallic, Vander Walls and ionic bond.

Electronic structure of materials: Free electron the theory, Metallic conduction. Energy bands, Brillouin zones, Temperature dependence of metallic conductivity. Semiconductors: Band theory, intrinsic and extrinsic semiconductors, Fermi levels, mobility and electrical conductivity, carrier diffusion and life time, P-N junction, biasing conditions, V-I characteristics, effects of temperature on diode characteristics. Magnetic materials: Properties, Dia-, Para- and Ferro-magnetism, Hysteresis loop, B-H curve, Energy losses in magnetic materials and their measurements. Soft and hard magnetic materials, ferrites.

Optics: Interference. Young's double slit experiment, fringe width, determination of wavelength of light and thickness of a transparent sheet. Interference due to reflection. Newton's ring. Determination of refractive

index of a liquid. Fresnel and Fraunhofer diffraction through single slit. Intensity of diffracted beam. Polarization: Polarized and Non-polarized light. Light polarization by reflection. Double refraction, Malus law, Intensity of polarized light.

Photoelectricity: Laws of photoemission and Einstein's equation. Photoelectric cell and its use. Introduction to superconductivity and its application.

**Phy 4122 Engineering Physics I Lab.**

**Credit 0.75**

Experiments based on Phy 4121.

**Chem 4121 Engineering Chemistry**

**Credit 3.00**

Atomic structure, Quantum numbers, Electronic configuration, Periodic table. Properties and uses of noble gases. Different types of chemical bonds and their properties. Molecular structures of compounds. Selective organic reactions.

Different types of solution and their compositions. Phase rule, phase diagram of monocomponent system. Liquid crystals. Properties of dilute solutions. Thermo chemistry; chemical kinetics, catalysis, chemical equilibriums. Ionization of water and pH concept. Electrical properties of solution.

Electrolysis and electroplating. Electroplating and its importance. Electrochemistry; Mechanism of electrolytic conduction. Transport number, Kohl – Rausch's law. Different types of cells, cell emf. Single electrode potentials, secondary cells or Accumulators, Lead accumulator and alkaline accumulator. Nernst Equation. Electrochemical cell; Redox number; electrode potential.

**Chem 4122 Engineering Chemistry Lab.**

**Credit 0.75**

Experiments based on Chem 4121.

**EEE 4101 Electrical Circuit I****Credit 3.00**

Basic concepts: Charge and current, voltage, power and energy, passive sign conventions. Circuit Elements: electrical power sources, ideal and practical sources, dependent and independent sources. DC analysis of resistive circuits: series, parallel and series-parallel circuits and Delta-Wye transformation: Kirchhoff's voltage and current laws, potential and current division rules with their applications and Tellegen's theorem. Network Analysis Methods: Branch current analysis, Nodal analysis and Mesh analysis, Supernode and Supermesh concepts. Network Theorem: Linearity and Superposition theorem, Source transformation, Thevenin's theorem, Norton's theorem and Maximum power transfer theorem.

Energy storage elements: Inductors (L) and Capacitors (C), steady state behavior of inductors and capacitors for DC sources, energy stored in inductors and capacitors. Different arrangements of inductors and capacitors.

Introduction to AC circuit analysis: AC waveform, average value, root mean squared value/ effective values, form factor, peak factor, phase relation and phasor concept. Steady state AC analysis: Effect of AC on R, L and C and their combinations; phase relation between voltage and current associated with R, L and C; impedance and admittance concepts, analysis of series, parallel and series -parallel and Delta-Wye circuits; AC power and power factor, phasor diagram.

Magnetic circuit and concepts: Magnetic flux density (B) and field intensity (H), permeability, reluctance, B-H curve and hysteresis, self-inductance and mutual inductance. Analysis of series, parallel and series- parallel magnetic circuits. Eddy current and core loss in a magnetic circuit.

**EEE 4102 Electrical Circuit I Lab.****Credit 1.50**

Hardware experiments and simulations based on EEE 4101.

## **Second Semester**

### **Hum 4222 Arabic II**

**Credit 1.00**

Reading comprehension, general exercise and revision of lessons; Nouns; singular, plural and various modifications; Use of verbs and pronouns, new words, different parts of speech.

### **Hum 4224 English II**

**Credit 1.00**

Listening & Speaking: Listening to dialogues, watching movies or documentaries; Conversations, Picture description, storytelling, etc.; Conversational traits. Reading: Reading for comprehension; Intensive reading; Time reading; Strategy-based reading; Reading comprehension exercises. Writing & Grammar: Conditionals, sentence change; Passivation, Reported speech; Modality, Prepositions; Adverbs, adjectives; Embedded and super-ordinate clauses, operators; Letters and paragraphs; Writing letters, e-Mails, reports, stories on familiar and unfamiliar subjects. Miscellaneous: Vocabulary development; Contextualized vocabulary items; Word-games; Culture in language; Tenses and usage.

### **Hum 4225 Professional Ethics and Legal Issues**

**Credit 3.00**

Professional Ethics: Introduction to Engineering ethics and professionalism; Moral Reasoning and Codes of Ethics; Moral Frameworks for Engineering Ethics; Ethical Problem-Solving Techniques; Engineering as Social Experimentation; Risk, Safety, and Accidents; Engineer's Responsibilities and Rights; Honesty and Research Integrity; Computer Ethics; Environmental Ethics; Global Issues; Cautious Optimism and Moral Leadership.

Legal Issues: Introduction to Legal Issues for engineering, business and industrial law, Law of contract, elements of valid contract, parties competent to contract, Sale of goods and higher purchase. Industrial law in Bangladesh, factories act, industrial relation ordinance. Workman compensation. All the issues are compared with the context of Islamic point of view.

**Math 4221 Mathematics III (Complex Variable, Credit 3.00  
Vector Analysis and Statistics)**

Complex Variable: Introduction to complex variable. Complex differentiation and integration. Calculus of residues. Contour integration and conformal mapping.

Vector analysis: Triple products, their geometric interpretation and application. Differentiation and integration of vectors. Line, surface, and volume integrals. Gradient, divergence, curl, and their physical significance. Green's theorem, Stoke's theorem. Divergence theorem and their applications.

Statistics and elementary quality control: Correlation. Regression, Elementary probability theory. Binomial, Poisson and Normal distribution. Tests of hypothesis. Application of elementary quality control to practical problems.

**Phy 4221 Engineering Physics II Credit 3.00**

Structure of matter: Classification of Solids; Crystalline and non-crystalline solids; unit cell, Crystal systems, Crystal structures, Atomic radius and crystal packing and packing density. Crystal directions, Planes and Planar spacing and cell edge. Bragg's law. Defects in Solids: Frankel and Schottky defects; Diffusion in solids.

Modern Physics: Special theory of relativity, Galilean relativity, Lorentz transformation equations, relativistic length, time and mass. Mass energy relation. Photo-electric effect. Compton scattering. Radioactivity. Radioactive decay law. Half-lives, mean life. Introduction to Nuclear fission and fusion. Nuclear power plant.

Thermal electricity: Thermocouple, Seebeck effect, Peltier and Thompson effect, Thermo-emf.

Wave and oscillation: Simple harmonic motion, damped simple harmonic oscillations, forced oscillations, resonance vibrations of membranes and columns. Combination and composition of simple harmonic motions, Lissajous' figures. Transverse and longitudinal nature of waves, travelling

and standing waves, intensity of wave, energy calculation of progressive and stationary waves, phase velocity, group velocity. Sound waves: velocity of longitudinal wave in a gaseous medium. Doppler effect. Architectural acoustics: Sabine's formula, requisites of a good auditorium.

**Phy 4222 Engineering Physics II Lab.**

**Credit 0.75**

Experiments based on Phy 4221.

**EEE 4201 Electrical Circuit II**

**Credit 3.00**

Review of single-phase steady state AC circuit analysis: Introduction to phasor method in AC circuit analysis. Nodal analysis, Mesh Analysis of AC circuits. Network theorems applied to AC circuit analysis. Series and parallel resonances. AC power calculation: Instantaneous power and average power, reactive power, power factor and power triangle.

Polyphase circuits: Voltage and current relations and power in balanced and unbalanced 3-phase circuits, 3-phase power measurement. Coupled circuits: Magnetically coupled circuits, mutual inductance, co-efficient of coupling, dot convention, energy in coupled circuits. Transient analysis of simple first and second order R-L-C circuits without and with sources.

Two-Port Networks: Impedance, Admittance, Hybrid and Transmission parameters of two port network, interconnections of two-port networks. Image impedance and characteristic impedance of tee (T) and pi ( $\pi$ ) sections. Matching networks.

Passive Filters: Frequency response. Fundamental filter equation and filter classification. Design specifications of low-pass, high-pass and band-pass filters. Conventional filters with constant-k and m-derived half and full sections. Introduction to modern filter design.

**EEE 4202 Electrical Circuit II Lab.**

**Credit 1.50**

Hardware and software based experiments based on EEE 4201.



**EEE 4203 Electronics I****Credit 3.00**

Introduction to semiconductors: P-N junction as a circuit element: Intrinsic and extrinsic semiconductors, operational principle of p-n junction diode, contact potential, current-voltage characteristics of a diode, simplified large and small signal models, iteration and graphical analysis, dynamic resistance and capacitance. Diode circuits: Half wave and full wave rectifiers, rectifiers with filter capacitor, characteristics of a Zener diode, Zener shunt regulator, clamping and clipping circuits.

Bipolar Junction Transistor (BJT) as a circuit element: current components, BJT characteristics and regions of operation, BJT as an amplifier, biasing the BJT for discrete circuits, small signal equivalent circuit models, BJT as a switch. Single stage mid-band frequency BJT amplifier circuits: Voltage and current gain, input and output impedance of a common base, common emitter and common collector amplifier circuits.

Introduction to Junction Field-Effect-Transistor (JFET). Metal Oxide Semiconductor Field Effect Transistor (MOSFET) as circuit element: structure and physical operation of an enhancement MOSFET, threshold voltage, Body effect, current-voltage characteristics of an enhancement MOSFET, biasing discrete and integrated MOS amplifier circuits, single-stage MOS amplifiers, MOSFET as a switch, CMOS inverter.

**EEE 4204 Electronics I Lab.****Credit 1.50**

Hardware and software based experiments on EEE 4203.

**Third Semester****Math 4321 Mathematics IV (Transform Techniques and Linear Algebra)****Credit 3.00**

Fourier Series: Fourier series expansion, evaluation of Fourier co-efficients, full range and half range series. Odd and even functions, harmonic analysis.

Laplace Transforms: Definition, elementary transformation and properties. Solution of differential and integro-differential equations using Laplace transformation and simple applications to circuit problems.

Linear Algebra: Euclidean n-space. Linear transformation from  $\mathfrak{R}^n$  to  $\mathfrak{R}^m$ . Properties of linear transformation from  $\mathfrak{R}^n$  to  $\mathfrak{R}^m$ . Real vector spaces and subspaces. Basis and dimension. Rank and nullity. Inner product spaces. Gram-Schmidt process and QR-decomposition. Diagonalization. Linear transformations. Kernel and Range. Application of linear algebra to electric networks.

### **EEE 4301 Power System I**

**Credit 3.00**

General system layout, Low voltage D.C. distribution system, A.C. distribution system, radial and ring systems, distributor aspects, sag calculations, poles and towers insulators, calculation of inductance and capacitance. Current and voltage relations on a transmission line, short lines, Medium-length lines, Long lines; cables, manufacture, laying and jointing of cables, insulation resistance and capacitance. Protection of transmission and distribution systems. Types of bus systems and their layout, Flexible AC transmission system (FACTS). High Voltage DC transmission system. Introduction to Smart Grid.

### **EEE 4302 Power System I Lab.**

**Credit 0.75**

Experiments based on EEE 4301.

### **EEE 4303 Electronics II**

**Credit 3.00**

Frequency response of amplifiers: Poles, zeros and Bode plots, amplifier transfer function, techniques of determining 3dB frequencies of amplifier circuits, frequency response of single-stage and cascade amplifiers, frequency response of differential amplifiers.

Operational amplifiers (Op-Amp): Properties of ideal Op-Amps, non-inverting and inverting amplifiers, inverting integrators, differentiator, weighted summer and other applications of Op-Amp circuits, effects of finite open loop gain and bandwidth on circuit performance, logic signal operation of Op-Amp, DC imperfections. General purpose Op-Amp: DC analysis, small-signal analysis of different stages, gain and frequency response of 741 Op-Amp. Op-Amp Design: design of a differential amplifier for a given specification, design of gain stages and output stages, compensation.

Negative feedback: properties, basic topologies, feedback amplifiers with different topologies, stability, frequency compensation. Active filters: Different types of filters and specifications, transfer functions, realization of first and second order low, high and bandpass filters using Op-Amps.

Signal generators: Basic principle of sinusoidal oscillation, Op-Amp RC oscillators, LC and crystal oscillators. Power Amplifiers: Classification of output stages, class A, B and AB output stages.

### **EEE 4304 Electronics II Lab.**

**Credit 1.50**

Hardware and software based experiments on EEE 4303.

### **EEE 4305 Energy Conversion I**

**Credit 3.00**

Review of electromagnetic induction. Basic principle of a Generator and a motor. Concept of torque angle. Power flow diagram for an elementary generator and motor.

D.C. Machines: Main constructional features, Function of brush and commutator. Armature winding systems: lap and wave windings. Different types of excitation. Armature reaction and methods of neutralizing armature-reaction. Losses and efficiency of D.C. machines. Determination of efficiency by practical methods.

D.C. Motors: Torque equation, back e.m.f., factors determining speed, characteristic Curves. D.C. motor starters, speed control. Application of D.C. motors.

Transformers, basic principle, construction, cooling methods, use of conservator and breather. Turns-ratio, EMF equation. Phasor diagram and equivalent circuit of a transformer on no-load and on-load. Voltage regulation, losses and efficiency. Transformer - tests. Auto-transformer and Instrument Transformers: (C.T. and P.T.), Parallel operation of transformers. Three-phase transformers. Gas Insulated Transformer (GIT), Cast Resin Transformer. Introduction to the design of single phase transformer

**EEE 4306 Energy Conversion I Lab.****Credit 0.75**

Experiments based on EEE 4305.

**EEE 4307 Digital Electronics****Credit 3.00**

Number system and Codes: General way of representing numbers, decimal, binary, octal and hexadecimal number systems and their representation, conversion of number from one system to another. Compliment in number system. Different Codes: BCD, Alphanumeric, Gray, Excess-3, ASCII and error detection codes.

Digital Logic: Boolean algebra, De-Morgan's Theorem logic gates and their truth tables. Canonical form of logic expression.

Simplification of logic expression: Algebraic method, K-Map and Quine-McClauskey method. Realization by using NAND/NOR gates.

Classification of logic systems: Combinational logic system. Combinational logic design using MSI and LSI. Adders, subtractors, Code Converters. Magnitude Comparator Encoder, Decoder, Multiplexer, De-multiplexer, ROM, RAM, Programmable logic Array (PLA), D/A and A/D converters with applications. Different types of digital storage media.

Implementation of basic static logic gates in CMOS and BiCMOS: DC characteristics, noise margin and power dissipation. Power optimization of basic gates and combinational logic circuits.

Sequential logic system: Flip-Flops, clocked RS, JK, Master Slave JK, D-type, T-type, Flip-Flops, Flip-Flop Design. Sequential logic Registers: Different types of Registers and their applications. Counters and their simplified design.

**EEE 4308 Digital Electronics Lab.****Credit 1.50**

Hardware and simulation based Experiments using Hardware Description Language (HDL) based on EEE 4307.

**Fourth Semester****Hum 4421 Science, Technology and Islam****Credit 2.00**

Definition: Science and Technology; Relation between science and technology; Development of science and technology till date; Islam, concept, origin and examples of main religions & their tenets; Comparative study among Islam, Christianity, Judaism, Hinduism and Buddhism; Relation between science and technology and Islam; Science and technology in different religions; Creation of the universe, Scientific approach the Big Bang Theory of primordial Ball; Approach through different religions, Islamic-Kun-Faya-Kun Concept; Scientific indications in the Holy Quran; Impact of science, technology and religion on society and social development; Contributions of Islamic civilization; Contributions of Western Civilization; Islam and the West.

**Math 4421 Random Signals and Processes****Credit 3.00**

Experiments, Models, and Probabilities: Set Theory, Applying Set Theory to Probability, Conditional Probability, Independence, Sequential Experiments and Tree Diagrams, Discrete Random Variables: Probability Mass Function, Families of Discrete Random Variables, Cumulative Distribution Function (CDF), Averages, Functions of a Random Variable, Expected Value of a Derived Random Variable, Variance and Standard Deviation, Conditional Probability Mass Function. Continuous Random Variables: The Cumulative Distribution Function, Probability Density Function, Expected Values, Families of Continuous Random Variables, Gaussian Random Variables, Delta Functions, Mixed Random Variables, Probability Models of Derived Random Variables, Conditioning a Continuous Random Variable. Pairs of Random Variables: Joint Cumulative Distribution Function, Joint Probability Mass Function, Marginal PMF, Joint Probability Density Function, Marginal PDF, Functions of Two Random Variables, Expected Values, Conditioning

by an Event, Conditioning by a Random Variable, Independent Random Variables, Bivariate Gaussian Random Variables. Random Vectors: Probability Models of N Random Variables, Vector Notation, Marginal Probability Functions, Independence of Random Variables and Random Vectors, Functions of Random Vectors, Expected Value Vector and Correlation Matrix, Gaussian Random Vectors. Sums of Random Variables: Expected Values of Sums, PDF of the Sum of Two Random Variables, Moment Generating Functions, MGF of the Sum of Independent Random Variables, Random Sums of Independent Random Variables, Central Limit Theorem, Applications of the Central Limit Theorem, The Chernoff Bound. Parameter Estimation Using the Sample Mean: Sample Mean: Expected Value and Variance, Deviation of a Random Variable from the Expected Value, Point Estimates of Model Parameters, Confidence Intervals, Hypothesis Testing: Significance Testing, Binary Hypothesis Testing, Multiple Hypothesis Test. Estimation of a Random Variable: Optimum Estimation Given Another Random Variable, Linear Estimation of X given Y, MAP and ML Estimation, Linear Estimation of Random Variables from Random Vectors. Stochastic Processes: Types of Stochastic Processes, Random Variables from Random Processes, Independent, Identically Distributed Random Sequences, The Poisson Process, The Brownian Motion Process, Expected Value and Correlation, Stationary Processes, Wide Sense Stationary Stochastic Processes, Gaussian Processes, Markov Chains.

**Math 4422 Random Signals and Processes Lab. Credit 0.75**

Experiments based on Math 4421.

**Phy 4421 Semiconductor Devices Credit 3.00**

Energy bands in semiconductor, Carrier statistics and Fermi level, carrier concentrations at equilibrium, temperature dependence of carrier concentrations, conductivity and mobility, effects of temperature and doping on mobility, high field effect, Hall effect, invariance of Fermi level. Carrier lifetime, direct and indirect recombination, quasi-Fermi level, photoconductive devices, Drift and diffusion of carriers, continuity and diffusion equations.

PN junction contact potential, equilibrium Fermi level, space charge, forward and reverse bias, carrier injection, minority and majority carrier currents,

avalanche and zener breakdown, time variation of stored charge, reverse recovery transient and capacitance. Metal-semiconductor junctions: Schottky barriers, rectifying and ohmic contacts.

Bipolar Junction Transistor: Basic principle of pnp and npn transistors, emitter efficiency, base transport factor and current gain, diffusion equation in the base, terminal currents, coupled-diode model and charge control analysis.

MOSFET: capacitance, energy band diagrams and flat band voltage, threshold voltage analysis and control, static C-V characteristics, MOSFET operation, I-V relationship and body effect.

Optoelectronic devices: Photo diodes. Light Emitting Diodes: Visible and infrared LED, principle, material. Semiconductor Laser.

### **EEE 4401 Power System II**

**Credit 3.00**

Representation of power systems, single line diagrams, impedance and reactance diagrams, per-unit system of calculations. Reactance of synchronous generators and its equivalent circuits, Symmetrical fault calculations, limitation of short circuit current using reactors.

Symmetrical components, positive, negative and zero sequence network of generators, transformers and lines, Unsymmetrical fault calculations.

Power and reactive power flow calculations of simple systems, load flow studies of large systems, control of voltage, power and reactive power.

### **EEE 4402 Power System II Lab.**

**Credit 0.75**

Experiments based on EEE 4401.

**EEE 4403    Communication Engineering I****Credit 3.00**

Overview of communication systems: Basic blocks in a communication system, Basic principles, fundamental elements, system limitations, message source, bandwidth requirements, transmission media types, and transmission capacity. Noise: Source, characteristics of various types of noise and signal to noise ratio.

Modulation: Base-band communication and concept of modulation and demodulation; Amplitude Modulation (AM): Double side band(DSB), single side band (SSB), vestigial side band (VSB), quadrature amplitude modulation (QAM); spectral analysis, generation and detection of each type; Angle modulation: Instantaneous frequency, Frequency modulation (FM) and Phase modulation (PM), spectral analysis, demodulation of FM and PM. Pulse modulation: Sampling, quantizing and encoding; pulse amplitude modulation (PAM); pulse width modulation (PWM); pulse position modulation (PPM) ; pulse code modulation (PCM); line coding; differential pulse code modulation; delta modulation. Digital modulation: Amplitude-shift keying-principle, ON-OFF keying; phase-shift keying (PSK), M-PSK, OQPSK, DPSK; frequency-shift keying (FSK), MSK, GMSK, M-QAM; Multiplexing: Time-division multiplexing (TDM) - principle, receiver synchronization, frame synchronization, TDM of multiple bit rate systems; frequency-division multiplexing (FDM) - principle, de-multiplexing;

Introduction to multiple access techniques: TDMA, FDMA, CDMA, OFDMA.

**EEE 4404    Communication Engineering I Lab.****Credit 0.75**

Experiments based on EEE 4403



**EEE 4405 Energy Conversion II****Credit 3.00**

Alternators: Basic Principle, construction, EMF equation, synchronous reactance, voltage regulation and parallel operation.

Synchronous motors: Basic principle, Starting methods, effect of excitation on armature current, V - curves.

Three-phase induction motor: Theory of rotating magnetic field. Construction of induction motor, rotor types. Speed and slip, starting torque, speed control, performance characteristic and equivalent circuit.

Single-phase induction motor: Basic principle, cross-field theory, double revolving field theory. Different methods of starting a single-phase induction motor.

Amplidyne and other special motors.

**EEE 4406 Energy Conversion II Lab.****Credit 0.75**

Experiments based on EEE 4405

**EEE 4416 Simulation Lab.****Credit 1.00**

Introduction to simulation tool environment, built-in functions and toolboxes, basic math operations, element by element operations, variables and assignment statement, conditionals, iteration and loops, arrays and vectors, matrix operations, logical operations, numerical methods analysis (Integration, 1st order ODEs, exponential growth etc.) using the simulation tool, implementation of electrical network theorems.

Plotting, histograms, plotting several graphs in one window, inserting labels, legends and titles, 3D and parametric plotting, GUI, introduction to graphical block diagramming tool for modelling and analyzing multi-domain dynamic systems.

**EEE 4418 Electrical Services Design****Credit 1.00**

Wiring system design, drafting, and estimation. Design for illumination and lighting. Electrical installations system design: substation, BBT and protection, air-conditioning, heating and lifts.

Design for intercom, public address systems, telephone system and LAN. Design of security systems including CCTV, fire alarm, smoke detector, burglar alarm, and sprinkler system.

Prepaid Energy Meter, Smart Metering System. A design problem on a multistoried building.

## **Fifth Semester**

### **Hum 4521 Engineering Management**

**Credit 3.00**

Basic management theory and practice, division of management structure into elemental functions, management functions and their inter-relationships, industrial organisation and organisational objectives, communications and job instructions, management of human resources, team work, leadership and human relationship, personnel system, performance appraisal and incentive scheme, manpower planning-forecasting labour demand, planning, scheduling and organising work, industrial relations-general framework, procedures for settlement of disputes, current development; industrial accident prevention, plant layout, working environment and material handling, work study, inventory control, basic costing and budgetary control.

### **Math 4521 Numerical Methods**

**Credit 3.00**

Mathematical modeling and Engineering Problem solving. Basic concepts of errors in numerical computation: Approximation and round-off errors, truncation errors and the Taylor series, error propagation. Roots of non-linear algebraic and transcendental equations: Bracketing method -bisection method and false-position method; Open method - Fixed point iteration, the Newton-Raphson method, the Secant method, Brent's method, finding multiple roots, systems of non-linear equations. Roots of polynomials: Muller's method and Baristow's Method. Numerical solution of algebraic equations: Gauss elimination method, LU decomposition and matrix inversion and Gauss Seidel method. Curve fitting: Least Square Regression, Interpolation and Fourier approximation. Numerical integration and differentiation. Numerical solution of ordinary differential equations: Euler's method and Runge-Kutta Methods. Numerical solution of partial differential equations: Finite difference (FD) methods, numerical stability, implicit FD method. Introduction to numerical optimization. Application of the numerical

techniques in solving Electrical and Electronic Engineering problems.

**Math 4522 Numerical Methods Lab.**

**Credit 1.50**

Experiments based on Math 4521.

**EEE 4501 Electromagnetic Fields and Waves**

**Credit 3.00**

Electrostatics: Coulomb's law, force, electric field intensity, electrical flux density. Gauss theorem with application, electrostatic potential, boundary conditions, method of images. Laplace's and Poisson's equations, energy of an electrostatic system, conductors and dielectrics.

Magnetostatics: Concept of magnetic field. Ampere's law, Biot-Savart law vector magnetic potential, energy of magnetostatics system, mechanical forces and torques in electric and magnetic fields. Graphical field mapping with applications, solution to Laplace's equations. Rectangular, cylindrical and spherical harmonics with applications. Maxwell's equations, their derivations, continuity of charges, concept of displacement current. Boundary conditions for time-varying systems. Potential used with varying charges and currents. Retarded potential, Maxwell's equations in different coordinate systems.

Relationship between circuit theory and field theory: Circuit concepts and the derivation from the field equations. High frequency circuit concepts, circuit radiation resistance, Skin effect and circuit impedance, Concepts of good and perfect conductors and dielectrics. Current distribution in various types of conductors, depth of penetration, internal impedance, power loss, calculation of inductance and capacitance.

Propagation and reflection of electromagnetic waves in unbounded media; Plane wave propagation polarization, power flow and Poynting's theorem. Transmission line analogy, reflection from conducting and conduction dielectric boundary; Display lines ion in dielectric, liquids and solids, plane wave propagation through the ionosphere, introduction to radiation.

**EEE 4505 Power Electronics**

**Credit 3.00**

Power semiconductor devices: structure and characteristics; snubber circuits, switching loss. Controlled rectifiers: full/half controlled converters, dual converters, and sequence control. AC regulator circuits, reactive power compensators. DC-DC converters, switching dc power supplies. Inverters: square wave and PWM types, filters, inverters for induction heating and UPS.

**EEE 4506 Power Electronics Lab.**

**Credit 1.50**

Experiments based on EEE 4505.

**EEE 4516 Microprocessor and Assembly  
Language Programming Lab.**

**Credit 1.50**

Introduction to microprocessors. Intel 8086 microprocessor: Architecture, addressing modes, instruction sets, assembly language programming, system design and interrupt. Interfacing: programmable peripheral interface, programmable timer, serial communication interface, programmable interrupt controller, direct memory access, keyboard and display interface.

**EEE 4518 Electrical and Electronic Workshop**

**Credit 1.00**

The purpose of this course is to allow students to do new and challenging experiment in emerging areas of Electrical Engineering. Students will complete a hardware project from various areas of electrical engineering with emphasis on digital electronics, communications, machines, drives and power systems, and electromagnetics.

**EEE 4521 Power System Protection Credit 3.00**

Purpose of power system protection. Criteria for detecting faults: over current, differential current, difference of phase angles, over and under voltages, power direction, symmetrical components of current and voltages, impedance, frequency and temperature. Instrument transformers: CT and PT. Electromechanical, electronic and digital Relays: basic modules, over current, I.D.M.T. characteristic, differential, distance and directional. Trip circuits. Unit protection schemes: Generator, transformer, motor, bus bar, transmission and distribution lines. Miniature circuit breakers and fuses. Circuit breakers: Principle of arc extinction, selection criteria and ratings of circuit breakers, types - air, oil, SF6 and vacuum.

**EEE 4522 Power System Protection Lab. Credit 0.75**

Experiments based on EEE 4521.

**EEE 4590 Industrial Training Credit 1.00**

Only for HDEE students.

## **5<sup>th</sup> Semester Elective Courses**

### **Power System Group**

**EEE 4523 Switchgear and Control Equipment I Credit 3.00**

Fundamentals of fault clearing, current interruption in A.C. circuit breakers, recovery voltage and prestriking voltage transients, switching of capacitor banks and unloaded lines, rated characteristics of circuit breakers arc extinction, arc interruption, arc extinction in different types of circuit breakers, arc-extinction devices, operating mechanism, control apparatus. Air break circuit breakers, bulk oil circuit breakers, minimum oil circuit breakers, Sulphur Hexafluoride (SF-6) circuit breakers, air blast circuit breakers, vacuum circuit breakers and their comparative study Control panels, basic control circuit devices. Alternator switchgear and control panels, automatic voltage control equipment. Apparatus for automatic voltage control equipment. Apparatus for automatic synchronization control.

Transformer tap changing control equipment. Automatic reclosing control of circuit breakers and oil circuit reclosers (OCRS). Gas Insulated Switchgear (GIS).

**EEE 4524 Switchgear and Control Equipment I Credit 0.75  
Lab.**

Experiments based on EEE 4523.

**EEE 4531 Energy Conversion III Credit 3.00**

Energy Conversion Processes: General introduction, energy sources, renewal and non-renewal energy sources. Principle of conservation of energy. Total energy concept. Direct Electrical Energy Conversion. Fuel cell, Thermo-electric, Electric, Electrostatic and piezoelectric energy conversions. Solar energy, Bulk power generation, photo electric and photo voltaic, solar cells; construction and characteristics.

Electro-mechanical Energy Conversion: Electrical to Mechanical, Mechanical to Electrical and Electrical to Electrical conversions. Bulk energy conversion devices; General formulation of equations. Introduction to generalized machine from field concept. Introduction to Electric Traction.

**EEE 4533 High Voltage Engineering Credit 3.00**

High voltage DC: Rectifier circuits, voltage multipliers, Van-de-Graaf and electrostatic generators. High voltage AC: Cascaded transformers and Tesla coils. Impulse voltage: Shapes, mathematical analysis, codes and standards, single and multi-stage impulse generators, tripping and control of impulse generators. Breakdown in gas, liquid and solid dielectric materials. Corona. High voltage measurements and testing. Over-voltage phenomenon and insulation coordination. Lightning and switching surges, basic insulation level, surge diverters and arresters.

## Communication Group

### **EEE 4541 Wireless Communication**

**Credit 3.00**

Electromagnetic wave concepts: EM wave types, plane wave, wave impedance, power flow, polarization.

Radio wave propagation: properties to support NLOS communication, advantages of low frequency communication, radio frequency spectrum regulation, ITU bands, ISM and UNII bands, ground wave, space wave and sky wave, path loss and shadowing, penetration, rain attenuation.

Introduction to Antenna radiation: basic antenna types, radiation pattern, gain, directivity, beamwidth, near and far field, antenna matching.

Diffraction: Knife-edge diffraction geometry, Fresnel zones.

Scattering: Rayleigh criterion, radar cross section model.

Propagation model: Free space model, two-ray model, log-distance path loss model, log-normal shadowing, Okumura-Hata model, Erceg model, COST 231-Walfish-Ikegami model, ITU model.

Indoor propagation model: attenuation factor model, partition losses.

Fading: large and small scale fading, multipath channel characteristics, power delay profile, channel sounding, delay spread, coherence bandwidth, Doppler spread, coherence time, flat and frequency selective fading, slow and fast fading.

Statistical channel models: Time-varying channel impulse response, Rayleigh and Rician fading, tapped delay line model, level crossing rate and average fade duration.

Space diversity and polarization diversity, interleaving, adaptive modulation and coding, interference-limited vs. noise-limited scenarios, near-far problem, hidden and exposed node problem.

Spread spectrum: FHSS, DSSS, THSS. Chipping, spreading and correlating

MIMO Systems: Narrowband multiple antenna system model, transmit precoding and receiver shaping, parallel decomposition of channel.

### **EEE 4542 Wireless Communication Lab.**

**Credit 0.75**

Experiments based on EEE 4541.

### **EEE 4551 Data Communication and Networking I Credit 3.00**

Overview of networking and the internet; core and access networks, data transfer: throughput, latency and round-trip time; physical media, circuit-switched and packet-switched networks, OSI model, WAN, MAN, LAN, PAN; Ethernet: physical layer connections, MAC ID, frame format, transmission and reception with CSMA/CD; Network Layer Protocols: IP – packet format, fragmentation and reassembly, global addressing scheme, Subnetting and Classless Addressing, Classless Interdomain Routing (CIDR), Address Translation (ARP), Host Configuration: DHCP, Error Reporting: ICMP; IPv6–packet format, auto-configuration and advanced routing capabilities, mobility support; Mobile IP – routing, route optimization; Virtual circuit technologies: Asynchronous Transfer Mode (ATM); virtual networks and tunnels, Virtual Private Networks (VPNs); bridges, switches and routers, forwarding table and routing table, spanning tree algorithm, Distance-vector routing: Routing Information Protocol (RIP); Link-state routing: Open Shortest Path First Protocol (OSPF); Area Border Router (ABR), multicast addresses, Multicast Routing: DVMRP, PIM and MSDP; Multiprotocol Label Switching (MPLS), ARPANET, NSFNET backbone, Autonomous System (AS), Inter-domain Routing: iBGP and eBGP. Transport Layer Protocols: User Datagram Protocol (UDP), Transmission Control Protocol (TCP) – segment format, three-way handshake, state-transition diagram, sliding window, reliable and ordered delivery, protecting against wraparound, keeping the pipe full, silly window syndrome, Nagle’s algorithm, adaptive retransmission, TCP extensions, Stream Control Transmission Protocol (SCTP); Transport for Real-Time Applications (RTP) – requirements, packet format, control protocol, RTCP; GPRS Tunneling Protocol (GTP); Name Resolution: domain hierarchy, Domain Name Server (DNS); Simulation of Ethernet and TCP/IP.

### **EEE 4553 Information and Coding Theory Credit 3.00**

Information Theory: Entropy and mutual information for discrete ensembles; Asymptotic equipartition property; Markov chains; Shannon’s noiseless coding theorem; Encoding of discrete sources. Data Compression, Discrete memoryless channels; Shannon’s noisy coding theorem and converse for discrete channels; Calculation of channel capacity and bounds for discrete channels; Differential entropy; Calculation of channel capacity for Gaussian



channels; Rate distortion function. Coding Theory: Linear Codes, distance bounds, generator and parity check matrices, error-syndrome table; a brief overview of rings and ideals; Cyclic codes, generator and parity check polynomials, Finite fields, applications of finite fields to cyclic codes; BCH codes and Reed-Soloman Codes; An overview of convolutional codes. Maximum likelihood decoding; Introduction to iterative codes and its sub-optimal decoding algorithms.

## **Electronics Group**

### **EEE 4571 Optoelectronics**

**Credit 3.00**

Optical properties in semiconductor: Direct and indirect band-gap materials, radiative and non-radiative recombination, optical absorption, photo-generated excess carriers, minority carrier life time, luminescence and quantum efficiency in radiation.

Properties of light: Particle and wave nature of light, polarization, interference, diffraction and blackbody radiation.

Light emitting diode (LED): Principles, materials for visible and infrared LED, internal and external efficiency, loss mechanism, structure and coupling to optical fibers.

Stimulated emission and light amplification: Spontaneous and stimulated emission, Einstein relations, population inversion, absorption of radiation, optical feedback and threshold conditions.

Semiconductor Lasers: Population inversion in degenerate semiconductors, laser cavity, operating wavelength, threshold current density, power output, hetero-junction lasers, optical and electrical confinement. Introduction to quantum well lasers.

Photo-detectors: Photoconductors, junction photo-detectors, PIN detectors, avalanche photodiodes and phototransistors.

Solar cells: Solar energy and spectrum, silicon and Schottkey solar cells.

Modulation of light: Phase and amplitude modulation, electro-optic effect, acousto-optic effect and magneto-optic devices.

Introduction to integrated optics.

**EEE 4573 Analog Integrated Electronics****Credit 3.00**

Review of FET amplifiers: Passive and active loads and frequency limitation. Current mirror: Basic, cascade and active current mirror.

Differential Amplifier: Introduction, large and small signal analysis, common mode analysis and differential amplifier with active load.

Noise: Introduction to noise, types, representation in circuits, noise in single stage and differential amplifiers and bandwidth.

Band-gap references: Supply voltage independent biasing, temperature independent biasing, proportional to absolute temperature current generation and constant transconductance biasing.

Switch capacitor circuits: Sampling switches, switched capacitor circuits including unity gain buffer, amplifier and integrator.

Phase Locked Loop (PLL): Introduction, basic PLL and charge pumped PLL.

**EEE 4575 Illumination Engineering****Credit 3.00**

Basic Illumination, The visible spectrum, Terms used in illumination, solid angle, illuminous flux, Luminous intensity, reduction factor, illumination, luminance, reflection ratio, specific output, specific consumption, laws of illumination, Inverse square law, Lambert's cosine law, illuminations calculations, Polar curves of light distribution, Roussean's figure. Design of lighting schemes and layouts, Photometry, light generation, Incandescent lamps, fluorescent lamps, Lighting circuits, Economics of lighting systems.

## Sixth Semester

### **Hum 4621 Technology, Environment and Society      Credit 3.00**

Definition of terminology – technology, environment, society and development; Inter-dependence of technology, environment, society and development; Growth of technologies and its contribution to human development; Current state of technology and its future use as an instrument of change in twenty first century; Impact of technology upon the environment, impact of the environment upon human changes in the global climates; Environment friendly technology, Technology and development; Renewable energy and environments. Technology and environment hazards, its remedy. Major hazards of industry. The improvement of working conditions in the industry.

### **EEE 4600 Project and Design      Credit 3.00**

Only for HDEE Students.

### **EEE 4601 Signals and Systems      Credit 3.00**

Signals and Systems: Classifications of signals and systems. Basic operations on signals. Commonly encountered elementary signals. Continuous-time (CT) and discrete-time (DT) systems. Basic system properties.

Linear Time-Invariant (LTI) Systems: The CTLTI systems –impulse response, zero input response and zero state response and convolution integral. The DTLTI systems –representation of DT signals in terms of impulses, impulse response and convolution sum.

Fourier Series Representation of Periodic Signals: CT and DT periodic signals, properties of continuous and discrete-time Fourier series, Fourier series and LTI systems.

Continuous-Time Fourier Transform: Properties, convolution and multiplication properties. Application of Fourier transform to LTI system analysis. Sampling and aliasing.

Laplace Transform: Region of convergence, inverse Laplace transform,

properties, analysis of LTI systems using Laplace transform.

**EEE 4602 Signals and Systems Lab.**

**Credit 0.75**

Experiments based on EEE 4601.

**EEE 4603 Measurement and Instrumentation**

**Credit 3.00**

Philosophy of sensors, transducer and instruments for signal to measure. Time measurement techniques : period, phase, time constant measurements;

Frequency measurement techniques : Frequency, ratio and product, high and low frequency measurements; Measurements and measurement systems, Errors in measurement and their statistical analysis, Dynamic characteristics of instruments, Sensing elements and transducers for measurement of motion, force, pressure, flow, temperature, light, vacuum, etc.;

Different types of transducers and their principle of operations and interfacing; Electronic Timers; 555 & OP-AMP and its applications. Measurement of resistance, inductance and capacitance-A.C and D.C bridge methods. Magnetic Measurements, Optoelectronic Measurement, Cathode Ray Oscilloscope (CRO), Instruments for Generation and Analysis of Waveform, Signal Analyzers, High Frequency Measurements.

Electronic instrumentation: Instrumentation and isolation amplifiers. Analog switches, S/H circuits, Data converters, V/F, F/V, A/D, D/A conversion. Data acquisition system. Noise in Electronic systems, design of low noise circuits, Programmable instruments and digital interfacing: serial, parallel. GPIB.

Industrial instrumentation: Introduction to Instrumentation systems. Static and dynamic characteristics of instruments. Non-destructive testing using Ultrasonic and eddy current.

Signal Conditioning and acquisition: Signal conditioning, signal transmission methods; Data loggers, PC based data acquisition systems, Interfacing and bus standards, programmable logic controllers and their industrial applications.

**EEE 4604 Measurement and Instrumentation Lab. Credit 0.75**

Experiments based on EEE 4603.

**EEE 4605 Microcontroller Based System Design Credit 3.00**

Introduction to the general structure of microcontrollers. Discussions on architectures, instruction sets, memory hierarchies, pipelining and RISC principles. Specific details of Intel8051/Atmega32/PIC18. Interfacing Peripherals: Keyboard, display, ADC, Programmable parallel port 8255, External memory, Motors, RTC etc.

**EEE 4606 Microcontroller Based System Design Credit 0.75  
Lab.**

Experiments based on EEE 4605.

## 6<sup>th</sup> Semester Elective Courses

### Power System Group

**EEE 4621 Electrical Installations** **Credit 3.00**

General requirement of installation, Symbols and Codes, electrical installation for residential, commercial and industrial buildings- preparation of Drawings for Electrical Installation: Consideration and selection of Conductors and Cables.

Installation of Electrical Machines, transformers and substations: Electrical Installation Protection, protection against lightning surges, over voltages and short circuits, selection of different types, cut-outs and circuit breakers.

**EEE 4622 Electrical Installations Lab.** **Credit 0.75**

Experiments based on EEE 4621.

**EEE 4623 Switchgear and Control Equipment II** **Credit 3.00**

Circuit breaker testing, type tests, routine tests, short circuit testing of circuit breakers, short circuit testing plants, insulation requirement and high voltage testing of circuit breakers, H.R.C. fuses and their applications, indoor switchgear, metalclad switchgear, low voltage control gear, contractors, low voltage circuit breakers, moulded case circuit breakers, isolators and earthing switches. Schemes of electrical layout and bus bar designs in different types of stations and sub-stations. Control of power by reactance, automatic supervisory control equipment. Automatic Control Equipment for stand by supply.

**EEE 4624 Switchgear and Control Equipment II** **Credit 0.75**  
**Lab.**

Experiments based on EEE 4623.

**EEE 4625 Utilization of Electrical Energy** **Credit 3.00**

Economics of Electrical Energy Utilization: Economics of Electric power

supply, general rule for charging the energy, Economical cross section of a conductor, ratings of a motor, temperature rise in a motor, power factor improvement, methods of reducing power factor occurrence, most economical power factor, economic choice of equipment.

Electric Heating: Salient features of electric heating, resistance heating, induction heating, electric arc heating, dielectric heating, methods of generating high frequency power

Illumination: Laws of illumination, classification of light sources, incandescent lamps, sodium vapor lamps, mercury vapor lamps, fluorescent lamps, design of illumination systems, indoor lighting schemes, outdoor lighting schemes, flood lighting, street lighting and energy saving lamps

Electrolytic Process: Principle of electro deposition, laws of electrolysis, applications of electrolysis.

Electric Drives and Traction, Electricity in Automobile, Refrigeration and Air-conditioning

**EEE 4526 Utilization of Electrical Energy Lab.      Credit 0.75**

Experiments based on EEE 4625.

**EEE 4631 Renewable Energy System      Credit 3.00**

Importance of renewable energy, sources. Statistics regarding solar radiation and wind speed. Insulation; geographical distribution, atmospheric factors, measurements. Solar cell; principle of operation, spectral response, factors affecting conversion efficiency, I-V characteristics, maximum power output. PV modules and arrays: stationary and tracking. PV systems: stand alone, battery storage, inverter interfaces with grid. Wind turbine generators: Types, operational characteristics, cut-in and cut-out speed, control, grid interfacing, AC-DC-AC link.

**EEE 4633 Nuclear Power Engineering      Credit 3.00**

Comparison analysis of conventional and non-conventional power plants; Non-conventional sources of power generation; solar and wind power, power from ocean, thermal, wave and tidal sources; Introduction to nuclear reactors and power plants; heat generation and removal; Types of nuclear

reactors, reactor coolants, Thermodynamic cycles for nuclear power stations, Shielding, Introduction to reactor reliability and safety analysis, Radioactive waste disposal; Economics of nuclear power; Introduction to nuclear fuel cycles.

### **EEE 4635 Power Plant Engineering and Economy Credit 3.00**

Introduction to thermal, hydro and nuclear power stations. Nuclear reactor, reactor construction and control. Power reactors. Central station Reactors. Nuclear hazards.

Variable load problems, plotting and analysis of load curves, chronological load curves and load duration curve. Energy load curve and its use. Load factor, capacity factor, demand factor, utilization factor, diversity factor etc. and their impact over the cost analysis of power generation and utilization. Load forecasting, selection of units and plant location.

Load shearing: Base load and peak load plants. Use of chronological load curves to distribute loads among units.

Power plant Economics: Economic operation of power plants. Input output curve, heat rate curve, and incremental rate curve. Use of incremental rate curve for optimum load scheduling. Transmission line loss, determination of loss co-efficient. Economic conductor selection, Kevin's law. Graphical method for location of distribution systems. Tariff and tariff design. Bus system. Importance of power control. Current limiting reactors. Different types of bus system layout. Forces on bus system in case of short circuit.



## **EEE 4637 Smart Grid**

**Credit 3.00**

Fundamental Elements of Design, analysis, and development of Smart Grid.

Introduction to the basic concepts of power systems along with the inherent elements of computational intelligence, communication technology and decision support system

The automation and computational techniques for guarantying adaptability and capability of handling new systems and components. The interoperability of different renewable energy sources to ensure minimum changes in the existing legacy system. Standards and requirements for designing new devices, systems and products for the Smart Grid.

Power flow analysis and optimization scheme for the generation, transmission, distribution, demand response, and reconfiguration for the Smart Grid.

## **Communication Group**

### **EEE 4641 Cellular Communication**

**Credit 3.00**

Evolution of cellular technologies, operating bands, radio access protocols for UMTS, HSPA and LTE, network architecture, protocol stack, RRC states.

Registration areas: PLMN, LA, RA, URA, TA, area update.

UE and network identities: IMSI, TMSI, GUTI, IMEI, RNTI, UE categories, ECGI, GUMMEI, PCI.

CDMA, OFDMA, SC-FDMA, spreading, OVFS codes, scrambling, radio frame, resource block, frequency reuse, sectoring, cell splitting, impact of cell size and cluster size, FFR, PFR and SFR, antenna at cell site, co-channel and adjacent channel interference, Radio Network Planning (RNP) objectives and techniques.

Heterogeneous network: macro, pico and femto cells, relay nodes, CSG.

Carrier aggregation, self-optimizing network (SON), load balancing, link budget calculations, logical, transport and physical channels. Radio bearer, QoS requirements, reference signals, MIB and SIB messages, PDU formats of MAC, RLC and PDCP sublayers, TM, UM and AM operations, ciphering and integrity protection, header compression, resource scheduling and allocation, link adaptation, synchronization, random access, paging, Hybrid ARQ (HARQ), Discontinuous reception (DRX), buffer status reporting,

power control, actions after powering up UE, service request, bearer setup, Voice Service: IMS, VoLGA, CSFB, MO and MT call setup and release, Short Message Service (SMS)

Cell reselection, Hard and Soft Handover: intra-frequency, inter-frequency and inter-RAT, measurement and reporting, handover preparation and command.

Overcoming dropped calls and packet loss, Multimedia Broadcast Multicast Service (MBMS), Device-to-Device (D2D), Public Warning System (PWS) UE positioning: OTDOA, A-GNSS, E-CID

### **EEE 4642 Cellular Communication Lab.**

**Credit 0.75**

Experiments based on EEE 4641.

### **EEE 4651 Data Communication and Networking II Credit 3.00**

Introduction to Wireless Networks, Wireless Links and Network Characteristics;

Different Wireless Networks: Based on Network Architecture – Infrastructure-based networks, Infrastructure-less networks, Based on Communication Coverage Area- WWANs, WMANs, WLANs, WPANs; Wireless Access Points;

IEEE 802.11: Architecture and standards, physical layer specifications, versions, network types, MAC protocol;

Ad Hoc Network: Wireless Ad Hoc Networks, Mobile Ad Hoc Networks (MANETs), Self-organized networks, Routing in Ad Hoc networks;

IEEE 802.15: Bluetooth and its specifications;

IEEE 802.16: WiMAX and its specifications;

Wireless Sensor Networks (WSN): WSN specification, roles of nodes: source, sink, actuator, sensing and communication range, energy consumption, clustering of sensors: regularly placed sensors, Heterogeneous WSNs, mobile sensors; application of sensor networks for smart environments; MANET vs. WSN; self-organization and localization in sensor networks;

Wireless Mesh Network (WMN);

Introduction to Delay-Tolerant Networking (DTN).

## **Electronics Group**

### **EEE 4661 Analog Filter Design** **Credit 3.00**

Filter preliminaries: Terminology; Magnitude and Phase responses; Classification (LPF, HPF, BPF, APF etc.)

Approximation Theory: Butterworth, Chebychev, Elliptic and Bessel Filters; Frequency Transformation.

Sensitivity: Basic concepts; Application to filters – Q sensitivity, wp sensitivity. Elements of passive network synthesis: Properties and synthesis of LC, RC driving point and transfer functions; Singly- and Doubly-terminated ladder networks.

Basics of Active Filter Synthesis: RC-OPAMP circuits, Biquad circuits based on negative feedback and positive feedback topologies; Active networks based on passive ladder structures; Effects of real OPAMPS on active filters.

Introduction to Switched-Capacitor Filters: The MOS switch; Simulation of resistors using Switched –Capacitor circuits.

### **EEE 4662 Analog Filter Design Lab.** **Credit 0.75**

Experiments based on EEE 4661.

## **Seventh Semester**

### **Hum 4721 Engineering Economics** **Credit 2.00**

Introduction to engineering economic decision, cash flow analysis and basic concepts of discounting, cost of capital, required ROR equivalence. Business mathematics: Investment appraisal criteria for economic decisions, present worth, internal rate of return, social consideration in investment, benefit-cost ratio Decisions involving depreciation and inflation, taxes, sensitivity analysis.

### **EEE 4700 Project and Thesis** **Credit 3.00**

The students are required to undertake a major in the field of Electrical and Electronic Engineering. The objective is to provide an opportunity to the students to develop initiative, creative ability, confidence and engineering

judgment. The results of the work should be submitted in the form of a report which include appropriate drawings, charts, tables, references etc.

**EEE 4701 Digital Signal Processing I Credit 3.00**

Introduction to digital signal processing (DSP): Discrete-time signals and systems, autocorrelation, cross correlation, impulse response, finite impulse response (FIR) and infinite impulse response (IIR) of discrete-time systems, difference equation, convolution, transient and steady state response.

Discrete transformations: Discrete Fourier series, discrete-time Fourier series, discrete Fourier transform (DFT) and properties, circular convolution, fast Fourier transform (FFT), inverse fast Fourier transform, z-transformation – properties, transfer function, poles and zeros and inverse z-transform.

Digital Filters: FIR filters- linear phase filters, specifications, design using window, optimal and frequency sampling methods; IIR filters- specifications, design using impulse invariant, comb-filter, introduction to multi-rate filtering.

Wavelet transform and its application.

**EEE 4702 Digital Signal Processing I Lab. Credit 0.75**

Experiments based on EEE 4701.

**EEE 4703 Communication Engineering II Credit 3.00**

Signals and Spectra: Classification of Signals, spectral density, autocorrelation, bandwidth of digital data, Formatting and baseband modulation: Formatting textual and analog data, Baseband transmission, PCM Waveform Types, Correlative coding, Baseband demodulation/detection: Error Performance Degradation, Detection of binary signals in Gaussian noise, Inter symbol Interference, Equalization. Bandpass modulation and demodulation: Digital bandpass modulation techniques, Phase shift keying, Detection of signals in Gaussian noise, Coherent detection, Noncoherent detection, Error performance for binary systems, M-ary signaling and performance, Symbol error performance,

Communications link analysis: Link margin. Channel coding: Waveform

coding, Types of error control, Structured sequence, parity check codes, Linear block codes, Error detecting and correcting capability, Well known block codes: Humming Codes, Extended Golay Codes, BCH Codes. Convolutional codes: Encoding, Convolution encoder representation, clixiterbi decoding.

Introduction to cellular telephony, satellite and optical communication.

**EEE 4704 Communication Engineering II Lab. Credit 1.50**

Experiments based on EEE 4703.

**EEE 4705 Control System Engineering I Credit 3.00**

Basic concepts: Notion of feedback, open- and closed-loop systems. Modeling and representations of control systems: Ordinary differential equations, Transfer functions, Block diagrams, Signal flow graphs,, Performance and stability: Time-domain analysis, Second-order systems, Characteristic-equation and roots, Routh-Hurwitz criteria, Frequency domain techniques: Root-locus methods, Frequency responses, Bode-plots, Gain-margin and phase-margin, Nyquist plots, M and N circles; Nichols chart. Compensator design: Proportional, PI and PID controllers, Lead-lag compensators. State-space concepts: introduction, representation, transformation.

**EEE 4706 Control System Engineering I Lab. Credit 0.75**

Hardware experiments & simulations based on EEE 4705.

**EEE 4790 Industrial Training Credit 1.00**

Industrial training programme will be organized by IUT during the session break in between 6<sup>th</sup> and 7<sup>th</sup> semesters and it is compulsory for all the students of B.Sc. Engg. (EEE). Duration of the training programme will be about four weeks.

## 7<sup>th</sup> Semester Elective Courses

### Power Systems Group

#### **EEE 4721    Advanced Power System Protection            Credit   3.00**

Non-directional and directional time graded system or feeder protection, Over current and earth fault protection of lines, Distance protection, Pilot wire protection, Carrier current protection, and Different types of surge protection, diverters and their selection. Performance of transmission lines with respect to lightning phenomena and stroke currents.

Different types of neutral and equipment grounding of power systems and selection. Earth resistance and their measurements.

Methods of analyzing generalizing and visualizing protective relay response: Superimposing Relay and System characteristics on R-X Diagram.

Power Swings and Loss of Synchronism, Effect on Distance Relays of Power Swing and Loss of Synchronism; Response of polyphase and single phase Directional Relays under different System conditions.

Application of Protective Relays for Bus Zone protection.

Introduction to SCADA system.

#### **EEE 4722    Advanced Power System Protection            Credit   0.75                   Lab.**

Experiments based on EEE 4721.

#### **EEE 4723    Computer Methods in Electric Power            Credit   3.00                   Systems**

Review of Matrix algebra. Incidence and network matrices: Introduction, Formation of bus admittance matrix – by method of inspection, by method of singular transformation, Formation of Bus Impedance Matrix by step by step building algorithm (with mutual coupling elements). Sparse matrix techniques

Three phase networks: Three phase balanced and unbalanced network elements, Algorithm for formation of three phase bus impedance matrix.

Load Flow Study: Special purpose load flow, fast decoupled load flow, dc power flow, backward and forward sweep

Short Circuit Studies, Sequence circuits. Short Circuit Current and Voltage

calculations for SLG, DLG, L-L and Three phase Faults.

Transient stability studies: Modified Euler's method, Runge-Kutta method, Milne's predictor corrector method. Representation of power system for transient stability studies – load representation, network performance equations. Solution techniques with flow charts.

Optimal power flow

**EEE 4724 Computer Methods in Electric Power Systems Lab. Credit 0.75**

Experiments based on EEE 4723.

**EEE 4731 Power System III Credit 3.00**

The stability problem of power system. Distinction between steady state and transient stability. The swing equation and its solution. Solution of networks for stability studies. Transient stability limits criteria. Two machine and multi-machine problems. Stability under different types of faults. Typical stability studies and methods of improving stability. The influence of swinging and out-of step operation upon protective relays. Rapid reclosing for improving stability.

### **Communication Group**

**EEE 4741 Optical Communication Credit 3.00**

Introduction to Optical Communication: Fiber optics – a review of the state of the art, Evolution of Lightwave Systems, Basic Concepts, Optical Communication Systems, Lightwave System Components.

Review of elementary optics, Elementary Theory of Propagation through Optical Fibers. Reflection, Refraction, Dispersion and Attenuation of Signals Propagation through Fiber Cables. Propagation characteristics of different kinds of fibers: Step-Index Fibers, Graded-Index Fibers. Wave Propagation, Maxwell's Equations, Fiber Modes: Single and Multi-mode Fiber. Dispersion in Single-Mode Fibers: Group-Velocity Dispersion, Material Dispersion, Waveguide Dispersion, Higher-Order Dispersion, Polarization-Mode Dispersion. Fiber Losses: Attenuation Coefficient, Material Absorption, Rayleigh Scattering, Waveguide Imperfections

Nonlinear Optical Effects (Four Wave Mixing, Cross-phase Modulation) &

Fiber Manufacturing.

Optical Transmitter: Basic Concepts: Radiative and Non-radiative Recombination, Emission and Absorption Rates. Light-Emitting Diodes, LED structures, Power–Current Characteristics. Laser in the Field of Optical Communication: Optical Gain, Feedback and Laser Threshold, Laser Structures, Laser Characteristics. Transmitter Design.

Optical detectors/ receivers: Basic Concepts. Detector Responsivity, Rise Time and Bandwidth. Common Photodetectors. Receiver Design: Receiver Noise, Sensitivity and sensitivity degradation, Receiver performance

Optical Amplifiers: Basic Concepts, Amplifier Applications, Raman Amplifiers and Erbium-Doped Fiber Amplifiers

Local data distribution, data transmission and telemetry: System Architectures

Point-to-Point Links, Distribution Networks and Local-Area Networks. Design Guidelines: Loss and Dispersion Limited Lightwave Systems, Power Budget, Sources of Power Penalty. Unguided and guided Optical Communication System & Economy of Optical Fiber System in Telecommunications.

Next generation fibers: Photonic crystal fibers, Nano-fiber tips & antennas, Higher-order modes, Air core fibers. Advanced Infrared propagation: radiant intensity, emitter beam pattern, detector sensitivity, link distance.

**EEE 4742 Optical Communication Lab. Credit 0.75**

Experiments based on EEE 4741.

**EEE 4751 Satellite and Radar System Credit 3.00**

Satellite Orbits and Launching: Kepler’s laws, Geostationary and non-geostationary orbits, Orbit perturbations; Radio Wave Propagation: Signal impairment: rain attenuation, atmospheric losses, ionospheric effects, Polarization, Antenna radiation patterns, Antenna arrays; Space Segment: Power supply, Attitude control, Station keeping, Thermal control, Transponders; Earth Segment: Receive-only TV antennas, Transmit-receive earth stations; Space Link: Link power budget equations, Intermodulation, Inter-satellite links, VSATS, GPS.

Radar Basics: Radar equation, minimum detectable signal, radar cross-section, pulse repetition frequency, range ambiguities. Introduction to MTI



and Pulse radar. Introduction to Tracking radars. Radar clutter. Different types of radar display. Overview of radar antennas.

## **Electronics Group**

### **EEE 4761 VLSI Circuits I Credit 3.00**

VLSI technology: Terminology and trends, MOS transistor characteristics, NMOS and CMOS inverters, dc and transient characteristics. Pass transistors and Pass gates. CMOS layouts and design rules, Complex CMOS gates, Resistance and Capacitance estimation and modeling Signal propagation delay, Noise margins and power consumption.

CMOS building blocks: adders, counters, parity generators, shift registers, multipliers, barrel shifters. Data paths, memory structures, PLAs and FPGAs. Speeding up technologies, BiCMOS circuits, GaAs technology.

### **EEE 4762 VLSI Circuits I Lab. Credit 0.75**

Experiments based on EEE 4761.

### **EEE 4763 Medical Electronics Credit 3.00**

Scope of Medical Electronics, Introductory concepts on basic body functions; Membrane potential – Nerve Action potential, Nerve Conduction Velocity (NCV), electrical RC equivalent circuit of nerve fiber.

Bioelectrical signal measurement, signal size and frequency content of different bio-electrical signals: Electromyogram (EMG), Electrocardiograph (ECG), Electroencephalogram (EEG), Evoked nerve, muscle and brain potentials. Noise and interference, and their elimination. Bioelectrical amplifier design, analysis for gain, input and output impedance, Common Mode Rejection Ratio, Patient safety, Microshock and electrical Isolation; Measurement of sensory and motor NCV through evoked action potentials, Electrical Nerve Stimulation, Design of a nerve stimulator. Transducers: Electrode as transducer, electrical activity at electrode-body interface, electrode equivalent circuit, electrode impedance.

Heart conduction block and artificial pacemaker, Heart fibrillation and Defibrillator; Temperature, flow and velocity sensors as needed in

Thermometry, and blood flow measurement; Blood Pressure measurement and monitoring, Blood Cell counters; Pulse beat monitor, Electronic Stethoscope, Focused Impedance Measurement, application ideas.

Ultrasound scanning techniques: A, B and M scans and applications, Use of LASER in medicine; Radioactivity and Radiotherapy; Hearing test, Correction of hearing; Basic concepts on Infrared heating, radio-frequency heating, Ultrasound heating, Bio-telemetry, Telemedicine; Basics of Clinical X-ray equipment, Fluoroscopy, Digital X-ray, CT scanner; Basics of Gamma Camera, SPECT, MRI and PET.

**EEE 4764 Medical Electronics Lab. Credit 0.75**

Experiments based on EEE 4763.

**EEE 4765 Embedded System Design Credit 3.00**

Embedded processing – Evolution, Issues and challenges;  
System and processor architecture: Von Neumann, Harvard and their variants; Memory architecture and devices; input-output devices and mechanisms; Instruction set and addressing Modes; interfacing of memory and peripheral devices – Functional and timing issues; Application specific logic design using Field programmable devices and ASICs; analog to digital and digital to analog converters; Bus I/O and networking considerations; Bus and wireless protocols;  
Embedded system software: Constraints and performance targets; real-time operating systems: introduction, Scheduling in real-time operating systems; Memory and I/O management: Device Drivers;  
Embedded software development: Flow, environments and tools, system specification and modeling, programming paradigms, system verification;  
Performance analysis and optimizations: Speed, power and area optimization; testing of embedded systems system design examples using microcontrollers, PLC and FPGA.

**EEE 4766 Embedded System Design Lab. Credit 0.75**

Experiments based on EEE 4765.

**EEE 4771 Compound Semiconductor and Heterojunction Device Credit 3.00**

Compound semiconductor: Zinc-blend crystal structures, growth techniques, alloys, band gap, density of carriers in intrinsic and doped compound semiconductors. Hetero-Junctions: Band alignment, band offset, Anderson's rule, single and double sided hetero-junctions, quantum wells and quantization effects, lattice mismatch and strain and common hetero-structure material systems.

Hetero-Junction diode: Band banding, carrier transport and I-V characteristics. Hetero-junction field effect transistor: Structure and principle, band structure, carrier transport and I-V characteristics. Hetero-structure bipolar transistor (HBT): Structure and operating principle, quasi-static analysis, extended Gummel-Poon model, Ebers-Moll model, secondary effects and band diagram of a graded alloy base HBT.

**Signal Processing and Interdisciplinary Group**

**EEE 4773 Artificial Neural Networks and Fuzzy Logic Credit 3.00**

Basic introduction to neural networks & fuzzy logic, development and implementation. Neural versus conventional computing. Neuron model and neural network architecture. Perceptron and perceptron learning rule. Signal and Vector Space, linear transformation. Learning processes. Supervised Hebbian learning, Widrow Hoff learning and back propagation learning algorithm. Recurrent networks. Self-organization Feature maps. Applications. Introduction to Fuzzy theory. Fuzzy Logic. Fuzzy logic in engineering.

**EEE 4775 Introduction to Robotics and Computer Vision Credit 3.00**

Introduction to computer vision and robotics. Image formation and analysis. Rigid body and coordinate frame transformations. Low- level vision and edge detection. Models for shading and illumination. Camera models and calibration.

3-D Stereo reconstruction. Epipolar geometry and fundamental matrix es.  
Motion estimation. Object Recognition.

## **Eight Semester**

### **Hum 4821 Business Communication Skill Credit 3.00**

The project cycle, project proposal and evaluation, contractual provisions, specification writing techniques.

Written communication: report writing, memoranda, letters, instructions, notice, personal filing systems etc.

Oral communication: listening skills, informal and formal meetings, power point, transparency based oral presentation, audio-visual communications.

Introduction to e-commerce.

### **Hum 4823 Sociology and Financial Accounting Credit 3.00**

#### **Sociology:**

Concepts of family and society (Islamic and non-Islamic): Growth of family and society; functions of family and society, obligation of family and social life. State and Nation: Elements of state and their characteristics; functions of the State, definition of the Nation, elements of the Nation and their characteristics; Relationship between Nation and State:-Islamic concept and Western concept. Government: different forms and types of Government. Citizenship: Rights and obligations. International Blocks and organizations: OIC, UNO, Commonwealth of Nation etc. Resources of Muslim world. Possible Socio-economics and cultural integration of Muslim Countries.

#### **Financial Accounting:**

Accounting its origin and development, Definition of accounting and bookkeeping, used and users of financial information, transactions, assets, liabilities, and the accounting cycle. Journal, Ledger, Cashbook, Trial balance, Income statement, Retained earnings, statement and balance sheet. Interpretation of financial statements, use of accounting information in project evaluation and other decision-making.

## **Phy 4821 Engineering Materials**

**Credit 2.00**

Classical theory of electrical and thermal conduction: Scattering, mobility and resistivity, temperature dependence of metal resistivity, Mathiessen's rule, thermal conductivity.

Introduction to quantum mechanics: Wave nature of electrons, Schrodinger's equation, one-dimensional quantum problems- infinite quantum well, potential step and potential barrier; Heisenberg's uncertainty principle, tunneling and quantum box.

Modern theory of metals: Determination of Fermi energy and average energy of electrons, classical and quantum mechanical calculation of specific heat.

Dielectric properties of materials: Dielectric constant, dipole moment, polarization mechanisms, internal field, Clausius-Mosotti equation, spontaneous polarization, frequency dependence of dielectric constant, dielectric loss and piezoelectricity.

Magnetic properties of materials: Magnetic moment, magnetization and relative permittivity, different types of magnetic materials, origin of ferromagnetism and magnetic domains, soft and hard magnetic materials, ferrites.

Introduction to superconductivity: Zero resistance and Meissner effect, Type I and Type II superconductors and critical current density.

## **EEE 4800 Project and Thesis**

**Credit 3.00**

The students are required to undertake a major project in the field of Electrical and Electronic Engineering. The objective is to provide an opportunity to the students to develop initiative, creative ability, confidence and engineering judgment. The results of the work should be submitted in form of a report which should include appropriate drawings, charts, tables, references etc.

## **EEE 4801 Power Generation**

**Credit 3.00**

Basis: power force, energy, work, electricity, units; energy system, power system; energy conversions.

Energy Sources: types, forms, natural, man-made, global energy and electricity use trend, source conservation.

Power Loads: types, demand factor, diversity factor, load curves, ideal load curve, peak load, base load, load factor, capacity factor, utilization factor, and load forecasting etc.

Electricity Generation: steam turbine, gas turbine, combined cycle, diesel, hydro and nuclear power plants; solar and wind bulk electricity.

Issues: environmental pollution, climate change, safety and legal requirements.

Plant Performance: efficiency, performance curves, heat rate, incremental heat rate, plant component performance, plant scheduling, captive generation, industrial cogeneration.

Plant economics and management criteria, electricity tariff, site selection etc.

Interconnected Power System: types, key issues, capacity savings, and power sharing among generating units.

## **8<sup>th</sup> Semester Elective Courses**

### **Power System Group**

**EEE 4831    Advanced Electrical Machines**

**Credit 3.00**

Special Machines: Interpretation of generalized machines from field concepts. Linear induction motor, stepper motor and control circuits, universal magnet motors, hysteresis motor, synchronous reluctance and switched reluctance motor, amplidynes and metadynes, synchros and control transformers, repulsion motor, permanent magnet DC motor, brushless DC motor, brushless synchronous machines.

DC and AC motor control: Semiconductor static power converters, fundamentals of DC and AC motor control by using semiconductor static power converters.

Electrical machine design: Design principles, single and three phase transformer design, design of single and three phase induction motors, application of computers in modern design of electrical machines.

**EEE 4833 HVDC Power Transmission Credit 3.00**

DC power transmission technology, HVDC converters system control, faults and protection, smoothing reactors, reactive power control, multi-terminal DC system, analysis of AC/DC dynamic simulation converters and DC systems.

**EEE 4835 Power System Operation and Control Credit 3.00**

Principles of power system operation: SCADA, convention and competitive environment. Unit commitment, static security analysis. State estimation, optimal power flow, automatic generation control and dynamic security analysis.

### **Communication Group**

**EEE 4841 Microwave Engineering Credit 3.00**

Transmission Lines: Voltage and current in ideal lines, Reflection, transmission, standing wave, impedance transformation, Smith chart, impedance matching, quarter-wave matching, single and double stub matching; Scattering parameters (S-parameters), Waveguides: General formulation for guided waves, parallel plate waveguides, rectangular waveguides, circular waveguides, different modes of propagation, power flow and losses in waveguides; Microstrip and Stripline: their structures and their characteristics impedances. Resonant Cavities: Simple rectangular resonant cavities, energy storage, losses and Q of the resonators, modes in rectangular resonators. Microwave Devices: Directional coupler, attenuator, phase shifter, circulator, isolator, etc. Microwave amplifiers and oscillators: Gain and stability, Stability circles, Single-stage transistor amplifier design, Design for maximum gain and specified gain, Low-Noise Amplifier (LNA) design.

**EEE 4842 Microwave Engineering Lab. Credit 0.75**

Experiments based on EEE 4841.

## **EEE 4851 Advanced Communication Techniques Credit 3.00**

Multicarrier Techniques for 4G Systems, characteristics of Multipath Fading Channels, Rayleigh and Ricean Fading Channels, frequency Selective and Frequency Nonselective Fading Channels, OFDM Characteristics, Radio Channel Model, Theoretical Bit Error Rate Analysis, Applications of OFDM, Combination of OFDM and CDMA. Channel Model, DS-SS System, Bit Error Rate Analysis, MC-SS System, Bit Error Rate Analysis, Design of MC-SS System, OFDM Adaptive Array Antennas.

Introduction to Optical Wireless Communication Systems (Li-Fi), Coded modulation techniques for optical wireless channels, Wireless optical CDMA communication systems, Multiple-input multiple-output (MIMO) techniques for indoor optical wireless communications, Free-space optical communications, Visible-light communications. Fibre-to-the Home (FTTH), radio over fibre (RoF), optical-wireless integration, high-capacity photonic switching networks.

Introduction of wireless sensor network, node architecture, communication interface, basic architecture framework, MAC layer, localization, Energy Efficient Information Processing, Routing, Fault Tolerant Algorithms Protocols, Quality of Service.

Overview of WiMAX, Technical Foundations of WiMAX, WiMAX Network Architecture, Link-Level Performance of WiMAX, System-Level Performance of WiMAX.

Introduction to Ultra Wideband network, UWB Features, UWB Antennas, Antenna Requirements, Ultra Wide Band Wireless Channels, impulse Response Modeling of UWB Wireless Channels, Path Loss, The IEEE UWB Channel Model, Frequency Modeling of UWB Channels, UWB Multiple Access Modulation, Pseudorandom Time Hopping, UWB Channel Capacity.

Voice over IP Technology, IP Signaling Protocols, VoIP Applications and Services.

Introduction to ZigBee, ZigBee Architecture, ZigBee Stack, ZigBee Applications.

Basic Software Defined Radio Architecture, Software Radio Applications, Hybrid Radio Architecture, Baseband Analog Circuits for Software Defined Radio, Software-Defined Radio Receivers for Deep Space Applications.

Introduction to Cognitive Radio Networking, Cognitive Radio Networking Preliminaries, Software Defined Radio as a Platform for Cognitive Radio,



Routing Schemes, Delay.

Basics of Radio Frequency Identification RFID Systems, RuBee networks, RFID middleware, Antenna Design for Ultrawideband RFID Systems, open source RFID-standard for wireless sensor network (DASH7).

Evolution of near field communication (NFC), NFC operating modes and essentials, Ubiquitous computing and NFC, General architecture of NFC.

Introduction to Indoor location services, Basic Positioning Techniques Building Modeling, Position Refinement, Trajectory Computing, Event Detection for Indoor location based service (LBS)

Introduction to Ipv6 over Low power Wireless Personal Area Networks (6LoWPAN), Application Protocols, Mobility and Routing.

## **Electronics Group**

**EEE 4861 VLSI Circuits II** **Credit 3.00**

VLSI MOS system design: Layout extraction and verification, full and semi-full custom design styles and logical and physical positioning. Design entry tools: Schematic capture and HDL. Logic and switch level simulation. Static timing. Concepts and tools of analysis, solution techniques for floor planning, placement, global routing and detailed routing. Application specific integrated circuit design including FPGA.

**EEE 4862 VLSI Circuits II Lab.** **Credit 0.75**

Experiments based on EEE 4861.

**EEE 4863 Bio Instrumentation** **Credit 3.00**

Human body: Cells and physiological systems. Bioelectricity: genesis and characteristics.

Measurement of bio-signals: Ethical issues, transducers, amplifiers and filters.

Electrocardiogram: electrocardiography, phono cardiograph, vector cardiograph, analysis and interpretation of cardiac signals, cardiac pacemakers and defibrillator. Blood pressure: systolic, diastolic mean pressure, electronic manometer, detector circuits and practical problems in pressure monitoring. Blood flow measurement: Plethymography and electromagnetic flow meter.

Measurement and interpretation: electroencephalogram, cerebral angiograph and cronical X-ray. Brain scans. Electromayogram (EMG). Tomograph: Positron emission tomography and computer tomography. Magnetic resonance imaging. Ultrasonogram. Patient monitoring system and medical telemetry. Effect of electromagnetic fields on human body.

**EEE 4864 Bio Instrumentation Lab. Credit 0.75**

Experiments based on EEE 4863.

**EEE 4865 Digital Filter Design Credit 3.00**

Basic concepts of digital filtering, Types of digital filters. FIR filter design methods: Z-transform, Transform function of discrete-time systems, Effect of the poles and zeros of the transfer function, FIR filter realization, Window functions, Finite word-length effects. IIR filter design: IIR filter realization, Reference analog prototype filter, Analog prototype filter to analog filter transformation, Low-pass filter, High-pass filter, Band-pass filter, Band-stop filter, Bilinear transformation. Filter design using VHDL and Implementing on FPGA.

**EEE 4866 Digital Filter Design Lab. Credit 0.75**

Experiments based on EEE 4869.

## **Signal Processing and Interdisciplinary Group**

**EEE 4867 Microprocessor System Design Credit 3.00**

Review of 8086 family of microprocessors. Instructions and data access methods in a 32 bit microprocessor; Representation of operands and operators; Instruction formats; Designing Arithmetic Logic Unit; Processor design: single bus, multi-bus architecture; Control Unit Design: hardwired, micro-programmed and pipe line; VLSI implementation of a microprocessor or part of a microprocessor design.

Microprocessor development systems: Controller for PLC; graphics processor, pen drive & external hard disk controller; arithmetic processor

(Intel 8087), FFT and array processor.

**EEE 4868 Microprocessor System Design Lab. Credit 0.75**

Experiments based on EEE 4867.

**EEE 4869 Digital Signal Processing II Credit 3.00**

Linear Prediction and Optimum Linear Filters: Innovations representation of a stationary random process, Forward and backward linear prediction, Solution of the normal equations, Properties of linear prediction-error filter, Autoregressive (AR) lattice and autoregressive moving average (ARMA) lattice-ladder filters.

Adaptive signal processing: FIR adaptive filters, steepest descent adaptive filter, LMS algorithm, convergence of LMS algorithms, Application: noise cancellation, channel equalization, adaptive recursive filters, recursive least squares.

Multirate signal processing: up-sampler and down-sampler, filters in sampling rate alternation systems; multi-stage design of decimator and interpolator, polyphase decomposition; arbitrary sampling rate converter, Lagrange interpolation, digital filter banks, uniform DFT filter banks, Nyquist filters, quadrature-mirror filter banks, perfect reconstruction two-channel FIR filter banks, multi-level filter banks.

Perfect reconstruction filter banks: Power symmetric, alias-free multi-channel and tree structured filter banks.

Wavelet transforms: Fourier Transform: Its power and limitations, Short time fourier transform, The gabor transform, Discrete time fourier transform and filter banks, Continuous wavelet transform, and Wavelet transform in ideal case.

**EEE 4870 Digital Signal Processing II Lab. Credit 0.75**

Experiments based on EEE 4865.

**EEE 4871 Biomedical Signal Processing Credit 3.00**

Introduction to Biomedical Signals: Origin of biosignals and their characteristics. Survey of major modalities for Biosignal processing: X-ray,

EEG, fMRI, ECG, Ultrasound, CT, MRI, PET, and SPECT. Noise and artefacts in biosignals.

Methods and techniques for analyzing biosignals: Introduction to linear systems: Fourier Transform, Radon Transform, Short term Fourier Transform, Advanced Time frequency Analysis (Wavelet Transform). Filtering, enhancement, restoration and registration of biomedical signals/images. Edge detection and segmentation of biomedical signals/images. Feature extraction of biosignals using popular clustering and classification techniques.

**EEE 4872 Biomedical Signal Processing Lab. Credit 0.75**

Experiments based on EEE 4871.

**EEE 4873 Control System Engineering II Credit 3.00**

Modeling of physical systems-Linearization and its consequences, Concepts of state and State-space. Derivation of state models from transfer functions and ordinary differential equations. Solution of state equations-Controllability and Observability. Classification of synthesis method of sensitivity and error analysis and stability. Design via state space, Performance measures like ISE, ITAE; Quadratic indices

State equations of digital systems with sample and hold, state equation of digital systems, digital simulation and approximation. Solution of discrete state equations: by z-transform, state equation and transfer function, state diagrams, state plane analysis. Stability of digital control systems. Digital simulation and digital redesign. Time domain analysis. Frequency domain analysis. Optimal linear digital regulator design. Digital state observer. Microprocessor control. Introduction to neural network and fuzzy control, adaptive control,  $H_\infty$  Control, nonlinear control.

**EEE 4874 Control System Engineering II Lab. Credit 0.75**

Hardware experiments & simulations based on EEE 4873.

**EEE 4875 Digital Image Processing Credit 3.00**

Introduction and Digital Image Fundamentals, Digital image Representation, Image Enhancement in the Spatial Domain, Image Enhancement in the Frequency Domain, Image Restoration, Image Compression, Image Segmentation, Object Recognition.

**MCE 4192 Mechanical Engineering Drawing Credit 0.75**

**EEE 4876 Digital Image Processing Lab. Credit 0.75**

Experiments based on EEE 4875.

**4.3.1.2 Courses Offered by Other Departments to EEE Students**

**Courses Offered by MCE Department**

Introduction to Engineering Drawings, Drawing instruments and their uses. Alphabet of lines and uses of Alphabet of lines, scales of drawing and dimensioning. Drawing geometrical figures including exercising of tangents. Orthographic views, arrangements of views in first angle and third angle. Exercising on orthographic views of straight and taper surfaced simple block. Isometric and oblique drawing of simple block. Full sectioning. Practice on lettering and numerals, lettering exercising on a composition.

**MCE 4391 Basic Mechanical Engineering Credit 3.00**

Study of fuels; Thermodynamic system, state, process and cycle. First and Second Laws of thermodynamics; Steam generating units with accessories and mountings; Study of steam generators and steam turbines.

Introduction to internal combustion engines and their cycles; Study of SI engines, CI engines and gas turbines with their accessories.

Refrigeration and air conditioning: their applications; Study of different refrigeration methods; Refrigerants; Refrigeration equipment: compressors, condensers, evaporators, expansion devices, other control and safety devices; Psychrometrics; Study of air conditioning systems with their accessories.

Types of fluid machinery; Study of impulse and reaction turbines: Pelton wheel and Kaplan turbine; Study of centrifugal and axial flow machines: pumps, fans, blowers and compressors; Study of reciprocating pumps.

**MCE 4392 Basic Mechanical Engineering Lab. Credit 0.75**

Experiments based on MCE 4391.

**Courses Offered by CSE Department**

**CSE 4271 Computer Programming Credit 2.00**

Introduction, Programming Concepts, Algorithm and Logic, Constants, Variables, Keywords and Data Types, Operators and expressions, Managing Input and Output Operations, Decision Making and Branching, Decision Making and Looping, Arrays, Multi-dimensional Arrays, Strings, User defined functions, Recursion, Structures and Unions, File Management in C,

Pointers, Dynamic Memory Allocation and Linked List, The Preprocessor and some advanced topics, Advanced data types and operators.

**CSE 4272 Computer Programming Lab. Credit 1.50**

Experiments based on CSE 4271.

**CSE 4575 Data Structures and Algorithms Credit 3.00**

Elementary data objects, Elementary data structures, arrays, lists, stacks, queues, link list, pointers, graphs, trees. Memory management. Sorting and searching, hash techniques.

Techniques for analysis of algorithms, Methods for the design of efficient algorithms: divide and conquer, greedy method, back tracking, branch and bound, Basic search and traversal techniques, lower bound theory, concept of NP-hard and NP-complete problems.

**CSE 4576 Data Structures and Algorithms Lab. Credit 0.75**

Experiments based on CSE 4575.

**CSE 4591 Discrete Mathematics Credit 3.00**

Set theory, Elementary number theory, Graph theory, Paths and trees, Generating functions, Algebraic structures, Semigraph, Permutation groups, Binary relations, functions, Mathematical logic, Propositional calculus and predicate calculus.

**CSE 4679 Operating System and System Programming Credit 3.00**

Introduction to O.S., evaluation of Operating Systems. Memory management: memory addressing, paging & storage multiplexing, virtual memory, Processing memory: process state, concurrent processing, synchronization, process scheduling, Deadlocks & its handling, protection system. Performance evaluation. Basic concepts of system programming, assembler, compiler, loader, technical design of assembler and compiler.





**CSE 4780 System Analysis and Design Lab. Credit 0.75**

Experiments based on CSE 4779

**CSE 4781 Object Oriented Programming Credit 3.00**

Concept of classes and objects, data and module encapsulation; polymorphism, inheritance, sub-typing, Advanced I/O, virtual function; object-oriented design; generic classes, static and dynamic binding, generic classes; exception handling, Namespace and standard template library.

Examples of languages for handling visual information; Examples of languages for handling visual interactions; visualization of data and information about data; visualization of programs and execution, visual interface design systems.

**CSE 4782 Object Oriented Programming Lab. Credit 0.75**

Experiments based on CSE 4781

**CSE 4871 Software Development Credit 3.00**

Students will work in groups or individually to produce high quality software including new I/O drives and similar projects involving operating system modules in different languages. Student will write structural programs and use proper documentation.

**CSE 4872 Software Development Lab Credit 0.75**

Experiments based on CSE 4871

**Courses Offered by CEE Department**

**CEE 4106 Civil Engineering Drawing Credit 0.75**

Introduction- lettering, numbering and heading; instrument and their use; sectional views and isometric views of solid geometrical figures. Plan, elevation and section of multistoried building; building services drawings; detailed drawing of lattice towers.



**EEE 6233    Advanced Analog Electronics                      Credit    3.00**

Feedback amplifier principles, linear wide-band low-noise feedback amplifier design, voltage and current regulators, switching regulators.

**EEE 6235    Advanced Solid State Devices                      Credit    3.00**

Semiconductor theory, development of mathematical analysis and systematic modeling of solid-state devices, characteristics and properties of solid-state devices, p-n junction, bipolar and unipolar transistors, noise models of active devices.

**EEE 6237    IC Processing and Fabrication                      Credit    3.00**  
**Technology**

Integrated circuit processing, solid state diffusion, diffusion technology, nonideal effects in diffusion, ion implantation, thermal oxidation, oxide for diffusion, masking, film deposition, photolithography and etching, device isolation, contacts and metallization; Si bipolar and MOSFET technologies, advanced bipolar processes, BiCMOS.

**EEE 6301    Power System Reliability                                      Credit    3.00**

Review of basic probability theory, Basic reliability concepts. Markovian model of generation unit, Development of load models, Probabilistic simulation of generating systems, Reliability indices: Recursive, segmentation and cummulant method to obtain loss of load probability (LOLP), Modeling for forecast uncertainty, Reliability evaluation: energy limited units, interconnected systems, composite transmission and generating system, and substation and switching stations.

**EEE 6303    Power System Planning    Credit    3.00**

Basic objectives of power system planning, Generation expansion planning process, Electrical demand forecasting: current demand forecasting approaches. Generation planning: economic analysis, expected energy generation, expected fuel cost, Booth-Baleriux, cummulant and segmentation methods, Probabilistic simulation of hydro and energy limited units, Expected energy production cost of interconnected systems, Economic









**EEE 6507    CISC Microprocessor System                    Credit    3.00**  
**Design**

Overview of advanced architecture CISC microprocessors and their associated support components with emphasis on incorporating these devices into both general purpose and embedded board level designs for multi-microprocessor systems utilizing open architecture system buses. 32-bit CISC microprocessors, memory management, floating point support, advanced peripherals, PLD- based “glue logic” design, performance evaluation, IEEE standard open architecture system buses, and various pertinent interface and networking standards.

**EEE 6601    Antennas and Propagation                    Credit    3.00**

Antenna theory; application of Maxwell’s equations to determine electromagnetic fields of antennas; radiation, directional arrays, impedance characteristics, aperture antennas; application of reaction concept and variational principles in antennas and propagation.

**EEE 6603    Microwave Devices and Circuits                    Credit    3.00**

Introduction to high frequency systems and circuits; fundamentals of microwave integrated circuits; microwave two-terminal and three-terminal solid-state devices; waveguide and microstrip solid-state circuits.

**EEE 6605    Semiconductor Lasers                                    Credit    3.00**

III-V compound semiconductor materials, spontaneous and stimulated emission in lasers; optical wave guiding equation solutions, quantum noise and spectral linewidth properties of lasers; principle and structure of photodiodes; III-V compound material technology.

**EEE 6607    Computational Electromagnetics                    Credit    3.00**

Review of techniques and applications in computational electromagnetics. Finite-Difference Time-Domain solution of Maxwell’s equations: boundary conditions, numerical stability, numerical dispersion, near-to-far field transformation. Introduction to Finite-Elements Technique: basis and weighting functions, Galerkin’s method, nodal and edge elements,





## **4.3.3 Contents of EEE Courses Offered to Other Departments**

### **4.3.3.1 Under-Graduate Programmes**

#### **EEE Courses Offered to MCE Department**

##### **EEE 4281 Basic Electrical Engineering Credit 3.00**

Electrical networks and circuit solution techniques, Delta-wye-Transformation, Circuit Theorems. Basic principle of generation of Alternating and Direct Current. Introduction to Phasor Algebra as applied to AC circuit analysis. Solution of AC circuits: RLC circuits- series and parallel Resonances, AC power analysis. Ampere's circuital law, B-H curve, solution of magnetic circuits, hysteresis and eddy current losses, an application of magnetic force, Introduction to magnetic circuits.

Three phase AC Circuits: Three phase EMF generation, delta and Y – connections, line and phase quantities, solution of three phase circuits, balanced supply voltage and balanced load, phasor diagram, measurement of power in three phase circuits.

DC Machines: Construction, EMF and Torque equations, Characteristics of DC generators and motors, speed control of DC motors and DC motor starters.

Transformers: Construction, EMF equation, ratings, phasor diagram on no load and full load, equivalent circuit, regulation and efficiency calculations, open and short circuit tests, auto-transformers.

Induction Motor: The revolving magnetic field, principle of operation, ratings, equivalent circuit, Torque-speed characteristics, speed control.

Synchronous Machines: Principle of operation, types, performances and characteristics.

##### **EEE 4282 Basic Electrical Engineering Lab. Credit 0.75**

Experiments based on EEE 4281

## **EEE Courses Offered to CSE Department**

### **EEE 4383 Electronic Devices and Circuits                      Credit 3.00**

Semiconductors, Junction Diode and characteristics, Bipolar transistor characteristics, Small signal low frequency h parameter model, Hybrid pie model.

Amplifiers, Darlington pairs, introduction to oscillators, differential amplifiers, operational amplifiers, linear application of Op-Amp, gain, input and output impedance, offset null adjustments, frequency response and noise. Introduction to JFET, MOSFET, PMOS, NMOS and CMOS: biasing and application in switching circuits. SCR, TRIAC, DIAC, PJT, CRT: characteristics and applications. Introduction to rectifiers, active filters, regulated power supply, stabilizer and UPS.

### **EEE 4384 Electrical and Electronic Technology                      Credit 0.75 Lab.**

Experiments based on EEE 4383.

### **EEE 4483 Digital Electronics & Pulse Techniques                      Credit 3.00**

Diode logic gates, Transistor switches, Transistor gates, MOS gates, Logic Families: TTL, ECL, IIL and CMOS logic with operation details, Propagation delay, Product and noise immunity, Open collector and high impedance gates,

Electronic circuits for flip-flops, Counters and register, Memory systems, PLAs, A/D and D/A converters with applications, S/H circuits, LED, LCD and optically coupled oscillators, Non-linear applications of Op-Amps, Analog switches.

Linear wave shaping: Diode wave shaping techniques, Clipping and Clamping circuits, Comparator circuits, Switching circuits, Pulse transformers, Pulse transmission, Pulse generation, Monostable, bistable and astable Multivibrators, Schmitt trigger, Blocking oscillators and time-base circuit, Timing circuits, Simple voltage sweeps, Linear current sweeps.

### **EEE 4484 Digital Electronics & Pulse Techniques                      Credit 0.75 Lab.**

Experiments based on EEE 4483

## **EEE Courses Offered to CEE Department**

### **EEE 4385 Electrical and Electronic Technology Credit 3.00**

Electrical Units and standards.

Electrical networks and circuit solution techniques, Delta-wye-Transformation, Circuit Theorems. Basic principle of generation of Alternating and Direct Current. Introduction to Phasor Algebra as applied to AC circuit analysis. Solution of AC circuits: RLC circuits- series and parallel Resonances, AC power analysis.

Ampere's circuital law, B–H curve, solution of magnetic circuits, hysteresis and eddy current losses, an application of magnetic force, Introduction to magnetic circuits.

Three phase AC Circuits: Three phase EMF generation, delta and Y – connections, line and phase quantities, solution of three phase circuits, balanced supply voltage and balanced load, phasor diagram, measurement of power in three phase circuits.

DC Machines: Specification and Characteristics of DC generators and motors.

Transformers: Introduction to Transformer, Auto Transformer, CT & PT and their characteristics, Specification, and Ratings.

Induction Motor: Classification, Specification, Torque-speed and its characteristics.

Introduction to Synchronous Machines and fractional Horse power motor.

Introduction to Electronic Switch devices, Rectifier, Amplifier, Oscillator and SMPS.

Introduction from Gate to Microcontroller and its applications.

Electric wiring for residential and commercial loads. Basic idea of Grounding and earthing of electric installation.











**EEE 4497 Digital Techniques II Credit 3.00**

Sequential logic system: Flip-Flops, clocked RS, JK, Master Slave JK, D-type, T-type, Flip-Flops, Flip-Flop Design.

Sequential logic Registers: Different types of Registers and their applications. Counters and their simplified design.

Timing Circuits: Application of logic gates in Timing Circuits, OPAM-application in timing circuits-use of IC-555 as timing circuits.

**EEE 4498 Digital Techniques II Lab. Credit 0.75**

Experiments based on EEE 4497.

**Bachelor of Science in Technical Education (B.Sc.TE)**

**2 Years Programme (DTE Stream)**

**Math 4529 Engineering Mathematics I Credit 3.00**

Fourier Series: Fourier series expansion, evaluation of Fourier co-efficients, full range and half range series. Odd and even functions, harmonic analysis.

Laplace Transforms: Definition, elementary transformation and properties. Solution of differential and integro-differential equations using Laplace transformation and simple applications to circuit problems.

Linear Algebra: Euclidean n-space. Linear transformation from  $\mathfrak{R}^n$  to  $\mathfrak{R}^m$ .

Properties of linear transformation from  $\mathfrak{R}^n$  to  $\mathfrak{R}^m$ . Real vector spaces and subspaces. Basis and dimension. Rank and nullity. Inner product spaces. Gram-Schmidt process and QR-decomposition. Diagonalization. Linear transformations. Kernel and Range. Application of linear algebra to electric networks.

Introduction to Numerical techniques and their applications.

**EEE 4591 Industrial Electronics I Credit 3.00**

Brief review of (i) Junction Diode, (ii) Schottky Diode, (iii) Zener Diode.

Introduction to thyristors: (i) SCR and (ii) TRIAC.

Introduction to trigger devices: (i) UJT, (ii) PUT, (iii) Schottky diode, (iv)

Silicon Unilateral Switch (SUS), (v) Diac; (vi) Silicon Bilateral Switch (SBS); (vii) Asymmetrical AC Trigger Devices.

SCR power control circuits for DC and AC.

TRIAC power control circuits for AC. Stabilized power supplies.

Controlled Rectification: with SCRs for resistive and inductive loads, Single phase half-wave and full-wave rectification.

Switch -mode power supplies.

Magnetic Amplifiers, Induction Heating, Dielectric Heating and Microwave Heating.

**EEE 4592 Industrial Electronics I Lab. Credit 0.75**

Experiments based on EEE 4591.

**EEE 4593 Instrumentation Engineering I Credit 3.00**

Introduction to Instrumentation: Review of Conversion of non- electrical signals into electrical signals. Linear wave shaping Technique. Switching circuits, pulse Transfers and its uses into instrumentation. Pulse Generations: Generation of monostable, bistable and astable pulses. Schmitt Trigger, Blocking Oscillators.

Timing Circuits: Ramps Circuits - Constant-current ramps, Boot strap ramps, Auto generation of CRT sweeps. Use of logic Gates in Timing Circuits.

Analog to Digital Converts (A/D), and Digital to Analog Convert (D/A) and their uses in Instrumentation.

**EEE 4594 Instrumentation Engineering I Lab. Credit 0.75**

Experiments based on EEE 4593.

**EEE 4595 Switchgear & Control Equipment I Credit 3.00**

Fundamentals of fault clearing, current interruption in A.C. circuit breakers, recovery voltage and restriking voltage transients, switching of capacitor banks and unloaded lines, rated characteristics of circuit breakers arc extinction, arc interruption, arc extinction in different types of circuit breakers, arc-extinction devices, operating mechanism, control apparatus.

Air break circuit breakers, bulk oil circuit breakers, minimum oil circuit breakers, Sulphur Hexafluoride (SF-6) circuit breakers, air blast circuit breakers, vacuum circuit breakers and their comparative study Control panels, basic control circuit devices. Alternator switchgear and control panels, automatic voltage control equipment. Apparatus for automatic voltage control equipment. Apparatus for automatic synchronization control. Transformer tap changing control equipment. Automatic reclosing control of circuit breakers and oil circuit reclosers (OCRS).

**EEE 4596 Switchgear & Control Equipment I      Credit 0.75  
Lab.**

Experiments based on EEE 4595.

**EEE 4597 Telecommunication Principles      Credit 3.00**

Introduction to communication systems: Fundamental elements, various signals and tones, different types of telephone instruments, different types of transmission media, bandwidth requirements, signal to noise ratio and rate of communication.

Information theory: Measure of information, error free communication over a noisy channel, channel capacity

Noise: External noise, internal noise, noise calculations and noise figure.

Modulation and demodulation: Baseband and carrier transmission. Amplitude modulation: SSB, DSB, VSB. Angle modulation: bandwidth of angle modulated wave, demodulation of AM and angle modulated waves.

Sampling and PCM: Sampling theorem, signal reconstruction, aliasing, quantization, PCM, DPCM, Companding.

Principles of digital data transmission: Simple digital communication system, line coding, pulse shaping, scrambling.

Multiplexing: FDM, FDM hierarchy. TDM, digital hierarchy (T1 carrier system)

Traffic analysis: Network traffic load and parameters, GOS, blocking parameters.

**EEE 4598 Telecommunication Principles Lab. Credit 0.75**

Experiments based on EEE 4597.

**EEE 4599 Power System I Credit 3.00**

Representation of power systems, single line diagrams, impedance and reactance diagrams, per-unit system of calculations. Reactances of synchronous generators and its equivalent circuits, Symmetrical fault calculations, limitation of short circuit current using reactors.

Symmetrical components, positive, negative and zero sequence network of generators, transformers and lines, Unsymmetrical fault calculations.

Power and reactive power flow calculations of simple systems, load flow studies of large systems, control of voltage, power and reactive power.

**Math 4629 Engineering Mathematics II Credit 3.00**

Complex Variable: Introduction to complex variable. Complex differentiation and integration. Calculus of residues. Contour integration and conformal mapping.

Vector analysis: Triplet products, their geometric interpretation and application. Differentiation and integration of vectors Line, surface, and volume integrals. Gradient, divergence, curl, and their physical significance. Green's theorem, Stoke's theorem. Divergence theorem and their applications.

Statistics and elementary quality control: Correlation. Regression, Elementary probability theory. Binomial, Poisson and Normal distribution. Tests of hypothesis. Application of elementary quality control to practical problems.

**EEE 4689 Peripherals and Microprocessor Based Design Credit 3.00**

Design of Simple-As-Possible Computers: Concepts of parallel bus, tri-state buffers, register-register transfer; design of SAP-1, SAP-1 instruction set, programming of SAP-1, instruction cycles, improvement of SAP-1 using microprogramming and variable machine cycle; SAP-2 architecture,



Temperature Transducer; (iv) Optical Transducer; (v) Flow Transducer; (vi) Strain gauge Transducer; (vii) Ultrasonic Transducer; (viii) Humidity Transducer; (ix) Hall-Effect Transducer; (x) Speed Transducer.

Voltage Multipliers. Electronic Timers: using (i) UJT, (ii) PUT, (iii) IC 555, (iv) IC XR 2240. DC Motor Controls: (i) DC Motor braking and plugging circuits, (ii) Speed Control of PM/Shunt Motors: Electronic speed control using armature voltage control method, solid state motor speed controllers SCR speed control circuits for PM/shunt motor: (a) simple SCR circuit, (b) SCR plus UJT circuit: Variation of a pulse-width modulation (PWM) speed control circuit. (iii) Speed control of series/Universal motor: circuits using (a) SCR (half-wave control), (b) TRIAC and DIAC (full-wave control). TRIAC control with hysteresis compensation. (iv) DC Motor Reversing Control: Balanced bridge reversing drive for PM or Shunt motors, Reversing Control Circuit for Series DC Motors. AC Motor Controls: (i) AC motor braking, (ii) Speed control of AC Motors: Introduction to variable frequency converter. A simple single phase inverter using (i) transistors. A simple single phase inverter using SCRs (McMurray Bedford commutation circuit). A simple Three-phase six-step Inverter circuit. A simplified single phase cycloconverter. Amplifiers in Industrial Electronics: DC Amplifiers, Balanced Push-pull DC amplifier, Chopper and Chopper Amplifier, Chopper stabilized DC Amplifier. Introduction to semiconductor Laser.

**EEE 4692 Industrial Electronics II Lab. Credit 0.75**

Experiments based on EEE 4691.

**EEE 4693 Instrumentation Engineering II Credit 3.00**

General instrumentation of plants: Operational amplifiers and their uses in instrumentation techniques. Digital instrumentation, Pneumatic instrumentation, signal conditioning. Data transmission. Indicating, recording and display systems.

Case studies of instrumentation of a Chemical processing plant.

**EEE 4694 Instrumentation Engineering II Lab. Credit 0.75**

Experiments based on EEE 4693.

**EEE 4695 Switchgear & Control Equipment II Credit 3.00**

Circuit breaker testing, type tests, routine tests, short circuit testing of circuit breakers, short circuit testing plants, insulation requirement and high voltage testing of circuit breakers, H.R.C. fuses and their applications, indoor switchgear, metalclad switchgear, low voltage control gear, contractors, low voltage circuit breakers, moulded case circuit breakers, isolators and earthing switches. Schemes of electrical layout and bus bar designs in different types of stations and sub-stations. Control of power by reactance, automatic supervisory control equipment. Automatic Control Equipment for stand by supply.

**EEE 4696 Switchgear & Control Equipment II Credit 0.75  
Lab.**

Experiments based on EEE 4695.

**EEE 4697 Radio Frequency Engineering Credit 3.00**

Introduction to radio communication, Radio frequency management.

Radio wave propagation and modeling, Free space propagation model, Radio wave reflections: Ground reflection model. Diffractions: Knife-Edge Diffraction Geometry, Fresnel Zones. Scattering: Rayleigh Criterion, Radar Cross Section Model. Log-Normal Shadowing. Outdoor Propagation Models: Okumura Model, Hata Model. Indoor Propagation Models: Attenuation Factor Model, Partition Losses.

Radio channel modeling, time-invariant and time varying channels. Stochastic and deterministic channel models. Frequency and time domain characterization of the radio channel. Small Scale Fading: Multipath channel characteristics, Delay spread, Coherence Bandwidth. Doppler Spread, Coherence time, Flat and Frequency Selective Fading, Slow and Fast Fading.

Radio planning for cellular mobile communication systems: Concept of frequency reuse and Co-channel reuse ratio. Co-channel and adjacent channel interference, cluster size and cell size, Sectoring, Cell splitting.

Link budget calculations for mobile communication.

Radio Frequency parameters for TDMA and CDMA systems: RxLev, RxQual. Spreading and Scrambling, OVFSF codes, Primary and Secondary Scrambling Codes. Control and traffic channels for GSM and UMTS. Radio interface protocols for call set up and handover.

Radio Antennas: dipole, folded dipole, yagi arrays, transmission loss, radiation pattern, gain, directivity of antennas, antenna matching.

**EEE 4698 Radio Frequency Engineering Lab. Credit 0.75**

Experiments based on EEE 4697.

**EEE 4699 Power System II Credit 3.00**

Power system stability involving two-machine systems, swing equation. Equal-area criterion of stability and its applications, solution of swing equation, factors affecting transient stability.

Economic operation of power systems: Distribution of load between units within a plant, Transmission loss as a function of plant Generation, Distribution of load between plants.

Types of bus systems and their layout, current limiting reactors.

Over-voltage in power systems, Lightning surges, switching surges, surge diverters.

## **Bachelor of Science in Technical Education (B.Sc.TE)**

### **1 Year Programme (HDEE Stream)**

**EEE 4700 Project & Thesis Credit 3.00**

The students are required to undertake a project in the related field of Electrical and Electronic Engineering. The results of the work should be submitted in the form of a report.



**EEE 4791 Control System Engineering Credit 3.00**

Concepts of an Engineering System and its representation. Dynamical System, their characterizations: mathematical models of physical systems; transfer function, signal flow diagrams. Steady state and transient response using place transform method; pole- zero concepts; error analysis. Stability analysis- Routh, Nyquist and Bode diagrams: Stability margins; M and N circles; Nichols chart; experimental determination for transfer functions. Root- locus method-plot and analysis. Design and compensation techniques, perform specifications, introduction to system compensation design with examples of lead and lag compensation.

**EEE 4792 Control System Engineering Lab. Credit 0.75**

Experiments based on EEE 4791.

**EEE 4793 Advanced Electronics I Credit 3.00**

Excess carriers in semiconductors, carrier lifetime, diffusion of carriers. Optical process in semiconductors: Radiative and non-radiative recombination, optical absorption, luminescence. Light Emitting Diodes: Visible and infrared LED, principle, material, construction. Photodetectors: photoconductor, junction photodiode, p-I-n photodiode, avalanche photodiode, phototransistor: Solar cell; Silicon solar cell, thin film solar cell, heterostructural solar cell, IC fabrication technology: Monolithic and hybrid circuits, device elements, charge transfer devices, LSI, VLSI, and ULSI techniques.

**EEE 4794 Advanced Electronics I Lab. Credit 0.75**

Experiments based on EEE 4793.

**EEE 4795 Microwave Theory & Technology I Credit 3.00**

H.F. Transmission lines, Smith chart. Impedance matching and applications. E.M. wave propagation. Reflection and refraction. Wave guides: Parallel Plane, rectangular, coaxial wave guides. Transit time effects: velocity modulation, space charge wave; Microwave

tubes, Klystron, Magnetron, Traveling wave Tube Amplifier. Wave guide components. Cavity resonators. Antennas and radiation. Hertzian dipole. Long antenna analysis, Radiation patterns, Rhombic and slot antenna. Antenna arrays. Introduction to antenna array design.

**EEE 4796 Microwave Theory & Technology I      Credit    0.75  
Lab.**

Experiments based on EEE 4795.

**EEE 4797 Power System Protection I                      Credit    3.00**

Introduction to power system protection, Explanation of the protective terms, Current transformers, HRC fuses, Electromechanical Relays, Over current relays, IDMT relays, Reverse power relays, Under frequency relays, Differential relays, Impedance, reactance and other types of distance relays, Static relays, Testing and maintenance of relays.

Non-directional and directional time graded system or feeder protection, Over current and earth fault protection of lines, Distance protection, Pilot wire protection, Carrier current protection, Protection of bus-bars, generators, transformers and motors.

Different types of surge protection, diverters and their selection. Performance of transmission lines with respect to lightning phenomena and stroke currents. Different types of neutral and equipment grounding of power systems and selection. Earth resistance and their measurements.

**EEE 4798 Power System Protection I Lab.                      Credit    0.75**

Experiments based on EEE 4797.

**EEE 4799 Power System Engineering I                      Credit    3.00**

Representation of power systems, single line diagrams, impedance and reactance diagrams, per-unit system of calculations. Reactances of synchronous generators and its equivalent circuits, Symmetrical fault calculations, limitation of short circuit current using reactors.

Symmetrical components, positive, negative and zero sequence network of

generators, transformers and lines, Unsymmetrical fault calculations. Power and reactive power flow calculations of simple systems, load flow studies of large systems, control of voltage, power and reactive power.

**EEE 4800 Project & Thesis Credit 3.00**

The students are required to undertake a project in the related field of Electrical and Electronic Engineering. The results of the work should be submitted in the form of a report.

**EEE 4881 Energy Conversion and Special Machines Credit 3.00**

Generalized energy conversion process, general principles of electromechanical energy conversion, energy storage, Interpretation of generalized machines from field concepts. Linear induction motor, stepper motor, universal magnet motor, shaded pole motor, hysteresis motor, synchronous reluctance and switched reluctance motor, amplidynes and metadynes, synchros. Introduction to electric traction.

**EEE 4891 Medical Electronics Credit 3.00**

Scope of Medical Electronics, Introductory concepts on basic body functions; Membrane potential - Nerve Action potential, Nerve Conduction Velocity (NCV), electrical RC equivalent circuit of nerve fiber.

Bioelectrical signal measurement, signal size and frequency content of different bio-electrical signals: Electromyogram (EMG), Electrocardiograph (ECG), Electroencephalogram (EEG), Evoked nerve, muscle and brain potentials. Noise and interference, and their elimination. Bioelectrical amplifier design, analysis for gain, input and output impedance, Common Mode Rejection Ratio, Patient safety, Microshock and electrical Isolation; Measurement of sensory and motor NCV through evoked action potentials, Electrical Nerve Stimulation, Design of a nerve stimulator. Transducers: Electrode as transducer, electrical activity at electrode-body interface, electrode equivalent circuit, electrode impedance.

Heart conduction block and artificial pacemaker, Heart fibrillation and Defibrillator; Temperature, flow and velocity sensors as needed in Thermometry, and blood flow measurement; Blood Pressure measurement and monitoring, Blood Cell counters; Pulse beat monitor, Electronic

Stethoscope, Focused Impedance Measurement, application ideas.

Ultrasound scanning techniques: A, B and M scans and applications, Use of LASER in medicine; Radioactivity and Radiotherapy; Hearing test, Correction of hearing; Basic concepts on Infrared heating, radio-frequency heating, Ultrasound heating, Bio-telemetry, Telemedicine; Basics of Clinical X-ray equipment, Fluoroscopy, Digital X-ray, CT scanner; Basics of Gamma Camera, SPECT, MRI and PET.

**EEE 4892 Medical Electronics Lab. Credit 0.75**

Experiments based on EEE 4891.

**EEE 4893 Advanced Electronics II Credit 3.00**

Metal-semiconductor junctions: Schottky and ohmic contacts. Semiconductor heterojunctions: structure, band alignment. Negative conductance microwave devices: Transit time devices, Gunn effect and related devices. Spontaneous and stimulated emission, Einstein relationship, threshold conditions, pumping methods. Semiconductor Laser: population inversion, confinement, turn-on delay, emission power, materials Biomedical electronics: active and rest potentials, electrocardiograph (ECG), pacemaker.

**EEE 4894 Advanced Electronics II Lab. Credit 0.75**

Experiments based on EEE 4893.

**EEE 4895 Power Station Credit 3.00**

Energy sources: Fossil fuels, nuclear fission; renewable sources - hydro, biomass, solar, wind, geothermal; pumped storage hydro.

Power Plant performance; connected load, demand factor, diversity factor, load factor, plant factor, utilization factor.

Plant performance and operating characteristics, efficiency, heat rate, incremental rate method, Station performance characteristics, Station incremental rate, capacity scheduling, Base load and peak load, Load division between steam and hydro stations, choice of power station and units.

Interconnected System: Capacity savings, power sharing amongst units for

economic allocation. Private generation: industrial co-generation, capacity generation. Site selection of Power Station.

Hydro - power stations and equipment, plant auxiliaries, plant operation.

Nuclear power stations - chain reactions, Moderators, types of reactors, shielding.

**EEE 4897 Microwave Theory & Tech II Credit 3.00**

Microwave oscillators and amplifiers: Principles of generation of millimeter and sub-millimeter waves; detailed analysis of Klystrons, Magnetrons and TWT amplifiers and backward wave oscillators. Harmonic generators, Gun-effect devices. Microwave circuits; Microwave network analysis and synthesis. Matrix representation and scattering matrix. Analysis of waveguide discontinuation of obstacles, junctions and cavities and strip lines. Methods of microwave precision measurements.

**EEE 4898 Microwave Theory & Tech II Lab. Credit 0.75**

Experiments based on EEE 4897.

**EEE 4899 Power System Protection II Credit 3.00**

Application of CT's and PT's for Protective Relays. Methods of analyzing generalizing and visualizing protective relay response: Superimposing Relay and System characteristics on R-X Diagram.

Power Swings and Loss of Synchronism, Effect on Distance Relays of Power Swing and Loss of Synchronism; Response of polyphase and single phase Directional Relays under different System conditions.

Application of Protective Relays for Bus Zone protection.

### **4.3.3.2 Post-Graduate programs**

#### **EEE courses offered to TVE Department**

#### **Master of Science in Technical Education (M.Sc.TE)**

##### **EEE 6191 Analysis and Synthesis of Circuits                      Credit 3.00**

Introductory network concepts. Definitions and symbols. Sign convention. Terminals and ports. Network functions. Complex frequency, driving point and transfer functions. Representation by poles and zeros. Properties of network function. Properties of Immittance function; Positive real function. Hurwitz Polynomials, Natural frequencies of network; Parts of a network function. (Magnitude and phase plots, Bode and Nyquist diagrams). Minimum phase transfer function. Calculation of a network function from prescribed real part. Imaginary part. Magnitude or phases. Synthesis of two element; Kind-one port LC, RC and RL one port network.

Two port networks. Classification and characterization of two ports. Two port parameters and natural frequencies. Interconnections of two ports. Common two port configuration. Scattering parameters. One end parameters; Iterative and Image Parameters. Filters; Type of filters. Frequency and impedance scaling. Image parameter. Filters; Design frequency transformation. Butterworth and Schembychev response. Insertion loss. Methods of net-work analysis. Block diagrams. Signals flow graphs, State variable techniques. Lattice networks. Bartlett's bisection theorem. Synthesis of Lattice network. Unbalancing of Lattice networks transmission characteristic. Signal distortions. Relationship between bandwidth and rise time, and between delay time and net-functions.

##### **EEE 6193 Electric and Magnetic Properties of                      Credit 3.00 Materials**

Atoms and aggregates of atoms; Crystals, waves in crystals; Schro-dinger wave equation, Quantum statics; Conductivity theory; Collision theory and conductivity of metals; Conductors; Carrier transport theory, P.N. Junction photo cells; Solar cells; Tunneling principles, Dielectric; polar and non-polar dielectrics; Langevin function, Clausius- Mossotti Equation, Ferro-electricity. Magnetic properties of materials; Magnetic moment; Domain wall motion

and coercive force in crystals; Polycrystalline and permanent magnetic materials; Magnetic resonance; Testing of magnetic materials; Super conductivity. Quantum electronics.

**EEE 6195 Modern Control Theory** **Credit 3.00**

General Introduction; State space concept: System design by State – Transition method concept of controllability and observability. Optimal control- variational calculus method; Principle of maximum and dynamic programming. Stochastic and adaptive control processor, On line computer control.

Vector norms; induced operator norms; Lp stability; the small gain theorem; performance/robustness trade-offs; L1 and Hoo optimal P control as operator norm minimization; H2 optimal control.

**EEE 6197 Applied EM Theory** **Credit 3.00**

Generalized approached to field theory: Introduction to reaction concept; Wave propagation through isotropic, anisotropic and gyrotropic media. Scattering of EM waves.

Antenna theory; application of Maxwell's equations to determine electromagnetic fields of antennas; radiation, directional arrays, impedance characteristics, aperture antennas; application of reaction concept and variational principles in antennas and propagation. Advance topics in EM Theory.

**EEE 6199 Solid State Devices** **Credit 3.00**

Solid State Diodes and Triodes: Visible and infrared LED, principle, material, construction. Photodetectors: photoconductor, junction photodiode, p-I-n photodiode, avalanche photodiode; Solid state microwave devices, Integrated electronic circuits: MOS transistor characteristics, NMOS and CMOS inverters.

**EEE 6291 High Voltage Engineering** **Credit 3.00**

High voltage supplies: A.C.: Cascaded Transformers. Tesla Coils; D.C: Valve Rectifier Circuit, Cascaded Rectifiers. Electrostatic Generators: Van-de-Graaff generators. Corona; Power loss calculations. Breakdown of

solid, liquid and gaseous dielectrics. Insulation tests. Standard specification. Impulse generators. Impulse wave shapes. Mathematical analysis and design consideration of impulse generators. Triggering of Impulse generators; Measurement of high voltages. Transmission Line design based on direct strokes, Insulation Coordination. Lightning arresters and protector tubes.

### **EEE 6293 Power System Stability**

**Credit 3.00**

The stability problem of power system. Distinction between steady state and transient stability. The Swing equation and its solution. Solution of networks for stability studies. Transient stability limits criteria. Two machine and multimachine problems. Stability under different types of faults. Typical stability studies and methods of improving stability. The influence of swinging and out-of step operation upon protective relays. Rapid reclosing for improving stability.

### **EEE 6297 Microwave Engineering**

**Credit 3.00**

H.F. Transmission lines; Smith chart: Impedance matching and applications. E.M. Wave propagation. Reflection and refraction. Wave guides: Parallel plane, rectangular, coaxial wave guides. Transit time effects; Velocity modulation; Space charge wave; Microwave tubes; Klystron, Magnetron, Travelling Wave Tube Amplifier. Wave guide components. Cavity resonators. Antennas and radiation. Hertzian dipole. Long antenna analysis Radiation patterns, Rhombic and slot antenna. Antenna arrays. Introduction to antenna array design.

### **EEE 6299 Microwave Theory and Techniques**

**Credit 3.00**

Microwave oscillators and amplifiers: Principles of generation of millimeter and sub-millimeter waves; Detailed analysis of Klystrons, Magnetrons and TWT amplifiers and Backward Wave Oscillators (BWO). Harmonic generators, Gunn-effect devices. Microwave Circuits: Microwave network analysis and synthesis. Matrix representation and scattering matrix. Analysis of waveguide discontinuation obstacles, junctions and cavities and strip lines. Methods of microwave precision measurements.



**EEE 4692 Advanced Electronics****Credit 3.00**

Designing Linear and nonlinear electronic circuits with operational amplifiers, Survey of available op-amps, Amplifications and limitations. Applications in Communication and instrumentation. Application of digital IC's in Communication circuits. Survey of logic families (TTL, ECL, CMOS, etc.) and their suitability for different applications. Design of Active filters, digital filters.

**EEE 6391 Engineering Analysis****Credit 3.00**

Professional methods of dealing with problems in Electrical and Electronic Engineering. Mathematical and Physical principles applied to problems of diverse topics. Linear spaces, N-dimensional and infinite dimensional vector spaces. Spectral Theory of Linear operators and their applications, Green's function and function concept and solution of engineering problems, variational methods. Simulation and optimization techniques. Statistical methods with application in electrical and electronic engineering.

**EEE 6393 Energy Conversion****Credit 3.00**

Energy Conversion Processes: General introduction, energy sources, renewal and non-renewal energy sources, principle of conservation of energy, energy balance equations; Total energy concept. Direct Electrical Energy Conversion: Introduction; Magneto-hydrodynamic (MHD); Fuel Cell; Thermo-electric, Ferro-electric electrostatic and Piezoelectric energy conversions; characteristics including efficiency, power densities, terminal properties and limitations.

Solar energy, Bulk power generation; Photo – electric and photo – voltaic, Solar Cell, Construction, characteristics including efficiency, applications and limitations. Electromechanical energy conversion: General introduction of Electrical to Mechanical, Mechanical to Electrical, Electrical and Electrical convention; Bulk energy conversion devices; General formulations of equations; Coordinate transformation and terminal characteristics.

**EEE 6395 Advanced Machine Design****Credit 3.00**

General Treatment of Electrical Machine Design. Review of standard procedures in design of D.C. Machines, A.C. Machines, transformers and

special machines, Optimization and synthesis of design procedures. Application of material balance and critical path principles in electrical design. Design economics and safety factors. Applications of computers in modern designs including the operation of the machine in non-linear ranges; Magnetic flux-plots and heat transfer process, etc. Mechanical Design of Electrical Machinery and relation between Mechanical and Electric Machine Design.

**EEE 6397 Statistical Theory of Communication      Credit 3.00**

Periodic and random signals. Stationary random processes. Elements of probability theory. Statistical Characteristics of messages and noise, Autocorrelation: Cross-correlation and spectral analysis. Determination of correlation functions and separation of signals from noise. Application of correlation techniques. Optimum filter, predictor, etc. Synthesis of optimum linear systems.

**EEE 6399 Telephone Traffic Theory                      Credit 3.00**

Introduction, Electronic switching: Basic switching system, Evolution of modern switching systems. Stored program control (SPC), centralized SPC and distributed SPC. Basic time division switching, time slot inter change, time multiplexed time switch. Types of switching systems; Nature of telecommunication traffic; Full availability; Limited availability and link system; Lost call cleared theory; Lost call held theory; Non-blocking networks; Characteristics of telecommunication network planning; Traffic measurement, Traffic prediction; Traffic simulation.

**EEE 6491 Generalized Machine Theory              Credit 3.00**

Introduction to generalized machine theory. Kron's Primitive machine; Moving to fixed-axis transformation; Parke's transformation; Three-phase to d-q transformation; Variable co-efficient transformation, other transformation; Matrix and tensor analysis of machine, Three-phase synchronous and induction machine; Two-phase servo motors; Single-phase induction motor. Smooth-motor two phase double excited machine; Smooth-air gap two-phase synchronous machine. Two-phase induction machine. The

n-m winding symmetrical machine; diagonalisation by a change of variable; Symmetrical three phase machine and special limiting cases.

**EEE 6493 Optimization of Power System Operation** **Credit 3.00**

General principles of optimization, its application to power system planning, design and operation. Probability analysis for bulk power security and outage data. Economic operation of power system-economic operation of thermal plants, combined thermal and hydro-electric plants. Theory of economic operation of inter connected areas. Development and application of transmission loss formulae for economic operation of power systems. Methods of optimum scheduling and dispatch of generation.

**EEE 6495 Computer Aided Power System Design** **Credit 3.00**

General review of network and matrix theories. Algorithms for formation of network matrices. Three- phase networks flux-linkage calculations, line parameter calculations, short-circuit calculations, load flow studies, system stability studies, prediction of reliability, over voltages and relay coordination.

**EEE 6497 Transients in Power Systems** **Credit 3.00**

Transients in simple electric and magnetically linked circuits; Fundamentals. Impacts of Switching on rotating machinery. Parallel operation of interconnected networks; Distribution of Power impacts. Interaction of Governor's in power systems. Overvoltage during power system faults. Systems voltage recovery characteristic. Effect of arc restriking on recovery voltage. Switching surges and overvoltage arrester requirements. Over voltages caused by sudden loss of load and by open conductor.

**EEE 6499 Laser Theory and Optical Communication** **Credit 3.00**

Quantum Electronics applied to electronic energy level transitions. Classical radiation and absorption by electronics. Narrow band spectra of solids; III-V

compound material technology. Spontaneous and stimulated emission in lasers; optical wave guiding equation solutions, quantum noise and spectral linewidth properties of lasers; Principles of Gaseous and solid state Laser devices. Laser rate equations. Principle and structure of photodiodes, Theory of Fiber optics. Fiber types and characteristics. Light sources: light emitting diode and laser diode. Detectors: PIN and avalanche photodetectors. Receiver analysis: direct detection and coherent detection, noises and limitations. Transmission limitations: chromatic dispersion, nonlinear refraction, scattering, four wave mixing, laser phase noises. Optical amplifier: laser and fiber amplifiers. Multichannel optical system: frequency division and wavelength division multiplexed systems.

### **Compulsory, Non-Credit**

#### **EEE 6190 Special Studies**

**Credit N/A**

The students are required to undertake a major project in the field of electrical and electronic engineering in their respective specialization. The objective is to provide an opportunity to the students to develop initiative, creative ability, confidence and engineering judgement. The results of the work should be submitted in the form of a report which should include approximate drawings, charts, tables, references etc.

#### **EEE 6290 Special Studies**

**Credit N/A**

The students are required to undertake a major project in the field of electrical and electronic engineering in their respective specialization. The objective is to provide an opportunity to the students to develop initiative, creative ability, confidence and engineering judgement. The results of the work should be submitted in the form of a report which should include approximate drawings, charts, tables, references etc.